

PSCE 350C B



3500



Reversible low-profile electrohydraulic scissors lift for cars, SUVs and vans

- **Robust structure of scissors**, offering great lateral stability
- **Hot galvanized base** as standard, painted scissors, runways and ramps
- **Alignment ensured** by two robust anti-torsion bars
- **Start lever** from zero position to maximum height



Ideal for tyre specialists, car workshops, and body repairers.



HYDRAULIC SYSTEM

Redundant hydraulic system with two cylinders per runway, without the need for compressed air and mechanical safety devices.



CONTROL UNIT

Low voltage control unit with “dead-man” control system.



RUNWAYS WITH FLAPS

Runways with hung flaps, which also serve as ramps to get the vehicle on. Their **“almond-shaped” structure** ensures good manoeuvrability even in wet conditions.

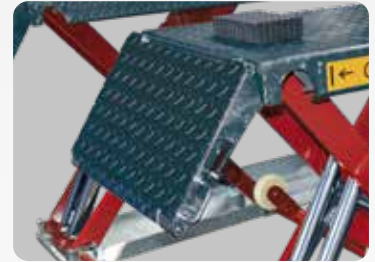

INCLUDED ACCESSORIES



RUBBER BLOCKS
Kit of 4 pcs H=40 mm

OPTIONAL ACCESSORIES



**8-4110028
KIT ON CARRIAGE**
Consisting of wheels and manual lever



**8-42300027
RUBBER BLOCKS**
Kit of 4 pcs H=80 mm

See separate catalogue for further accessories.

TECHNICAL DATA

Lift capacity	3500 kg
Maximum lifting height	895 mm
Minimum lifting height	105 mm
Working height	1000 mm + tamponi gomma
Lifting/lowering time	16 s
Hydraulic unit	2.2 kW
Voltage	230/400V - 3Ph - 50/60Hz

DIMENSIONS

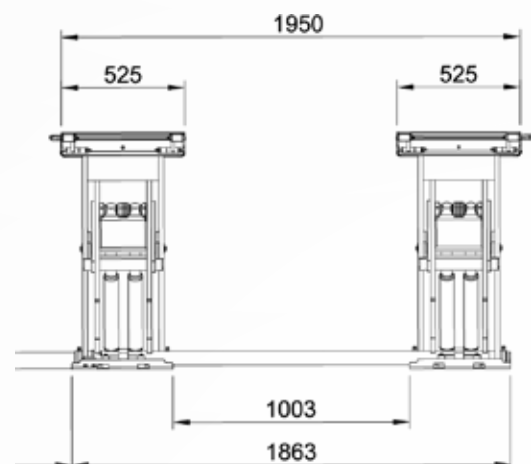
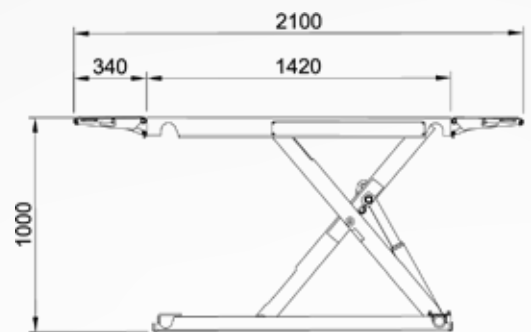

The manufacturer reserves the right to modify the features of its products at any time.



NEXION SPA - ITALY
www.sice.it - sice@sice.it



Designed in
ITALY

