

Serie PSR 50 - PSR 43



5000



4300



EN

Electro-hydraulic scissor lift

- Electro-hydraulic scissor lift available with different runway configurations.
- An advanced electronically controlled hydraulic circuit guarantees perfect runway alignment.

IT

Sollevatore elettroidraulico a forbice

- Sollevatore elettroidraulico a forbice disponibile in diverse configurazioni di pedane.
- Un evoluto circuito idraulico, controllato elettronicamente, garantisce un perfetto allineamento delle pedane.

DE

Elektrohydraulische Scherenhebebühne

- Elektrohydraulische Scherenhebebühne, in verschiedenen Konfigurationen der Fahrschienen lieferbar.
- Ein moderner elektronisch gesteuerter Hydraulikkreis garantiert eine präzise Achsvermessung der Fahrschienen.

Serie PSR 50 - PSR 43

- Flat runways or with slip plates
- Pedane piane oppure con piatti oscillanti
- Flachen Schienen oder mit Schiebepplatten

Lift-Table

- Wheel alignment version
- Versione per assetto ruote
- Hebebühne für Achsvermessung

- Prova giochi
- Play detector
- Gelenkspieltester



- alphanumeric display
- display alfanumerico
- alphanumerisches display

AVAILABLE VERSIONS VERSIONI DISPONIBILI VERFÜGBARE VERSIONES	PSR 50	PSR 50 CT	PSR 50 CT PT2	PSR 50 CT PT6	PSR 50 PT2	PSR 50 PT6	PSR 50 LT	PSR 50 CT LT	PSR 50 LT PT2	PSR 50 LT PT6	PSR 50 CT LT PT2	PSR 50 CT LT PT6	PSR 43 CT	PSR 43 PT2	PSR 43 PT6	PSR 43 CT LT	
Flat runways - Pedane piane - Flachen Schienen	✓				✓	✓	✓		✓	✓			✓		✓	✓	
Lift-Table							✓	✓	✓	✓	✓						✓
Wheel alignment version - Versione per assetto ruote - Hebebühne für Achsvermessung		✓	✓	✓					✓					✓			✓
2-movement play detector - Prova giochi a 2 movimenti - Gelenkspieltester mit 2 Bewegungen			✓		✓				✓		✓				✓		
6-movement play detector - Prova giochi a 6 movimenti - Gelenkspieltester mit 6 Bewegungen				✓		✓			✓		✓					✓	



- EN** — • The control electronics feature an **ALPHANUMERIC DISPLAY** allowing access to a number of user functions, including viewing lift height from ground and setting the desired arrest height for the lift
- IT** — • L'elettronica di controllo è dotata di un **DISPLAY ALFANUMERICO** con numerose funzioni per l'utente, fra cui la possibilità di visualizzare l'altezza del ponte e impostare l'arresto del sollevatore all'altezza desiderata.
- DE** — • Die Steuerelektronik verfügt über ein **ALPHANUMERISCHES DISPLAY** mit zahlreichen Benutzerfunktionen, wie der Möglichkeit, die Höhe der Hebebühne anzuzeigen und ein Anhalten der Hebebühne auf der gewünschten Höhe einzustellen.



- EN** — • To enable the wheel alignment cycle, the lift parking racks are adjustable; the electronics control whether the runways lift parking racks are engaged on the same teeth.
- IT** — • Le cremagliere di stazionamento, per eseguire il ciclo assetto, sono regolabili; l'elettronica controlla che le cremagliere delle due pedane siano ingranate sullo stesso dente.
- DE** — • Die Zugstangen für die Feststellung zur Ausführung des Achsvermessungszyklus sind einstellbar; die Elektronik steuert, dass die Zugstangen der beiden Schienen an dem selben Zahn eingreift sind.



- EN** — • The recesses for the turn plates and slip plates are adjustable (pre-set in factory) to ensure perfect planarity of the runways.
- IT** — • L'incavo piatti rotanti e le piastre oscillanti sono regolabili (operazione eseguita in fabbrica) per ottenere una perfetta planarità delle pedane.
- DE** — • Die Aussparung für die Drehteller und die Schiebepplatten sind einstellbar (Einstellung im Werk durchgeführt), um eine vollkommene Ebenheit der Schienen zu erreichen.

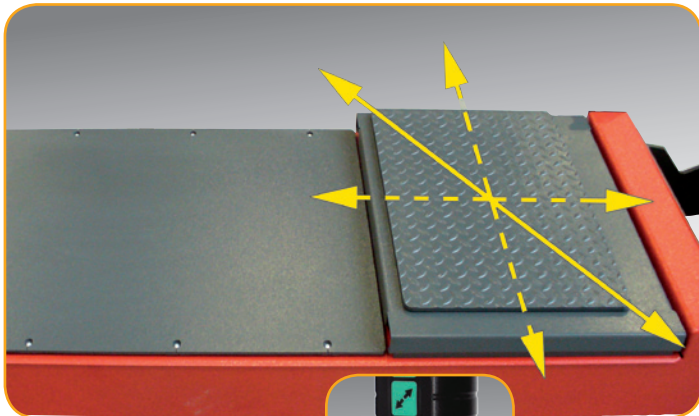

- EN** — • Two-movement and six movement play detector versions are available (**PT2-PT6**). Versions with the six movement play detector (PT6) are also available with Wi-Fi wireless control.

- IT** — • Sono disponibili **due versioni di provagiochi**, rispettivamente a due e sei movimenti (**PT2-PT6**). Le versioni con provagiochi a sei movimenti (PT6) possono essere dotate di comando senza cavo Wi-Fi.

- DE** — • Es sind zwei Ausführungen des Gelenkspieltesters mit jeweils zwei und sechs Bewegungen lieferbar (**PT2-PT6**). Die Ausführungen mit Gelenkspieltester mit sechs Bewegungen (PT6) können mit einer kabellosen Wi-Fi-Steuerung ausgestattet werden.

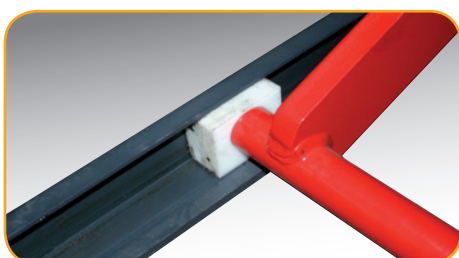

- EN** — • Plastic sliding shoes
- IT** — • Pattini di scorrimento in materiale plastico
- DE** — • Gleitböcke aus Kunststoff.

Serie PSR 50 - PSR 43



- EN** — • In the versions for wheel alignment without lift-table the vehicle's front axle is positioned in a lift's fixed point (where there are the turntables), **independently from the vehicle wheel base** and without any further regulation.
- IT** — • Nelle versioni per assetto senza lift-table l'asse anteriore del veicolo viene posizionato in un punto fisso del sollevatore (dove sono presenti i piatti rotanti), **independente dal passo del veicolo** e senza nessuna regolazione successiva.
- DE** — • Im Bereich den Versionen für die Achsvermessung ohne „Lift-Table“ die Vorderachse des Fahrzeuges wird in einem fixierten Punkt (wo die Drehteller liegen) positioniert, **unabhängig von dem Radstand** und ohne weitere Anpassungen.

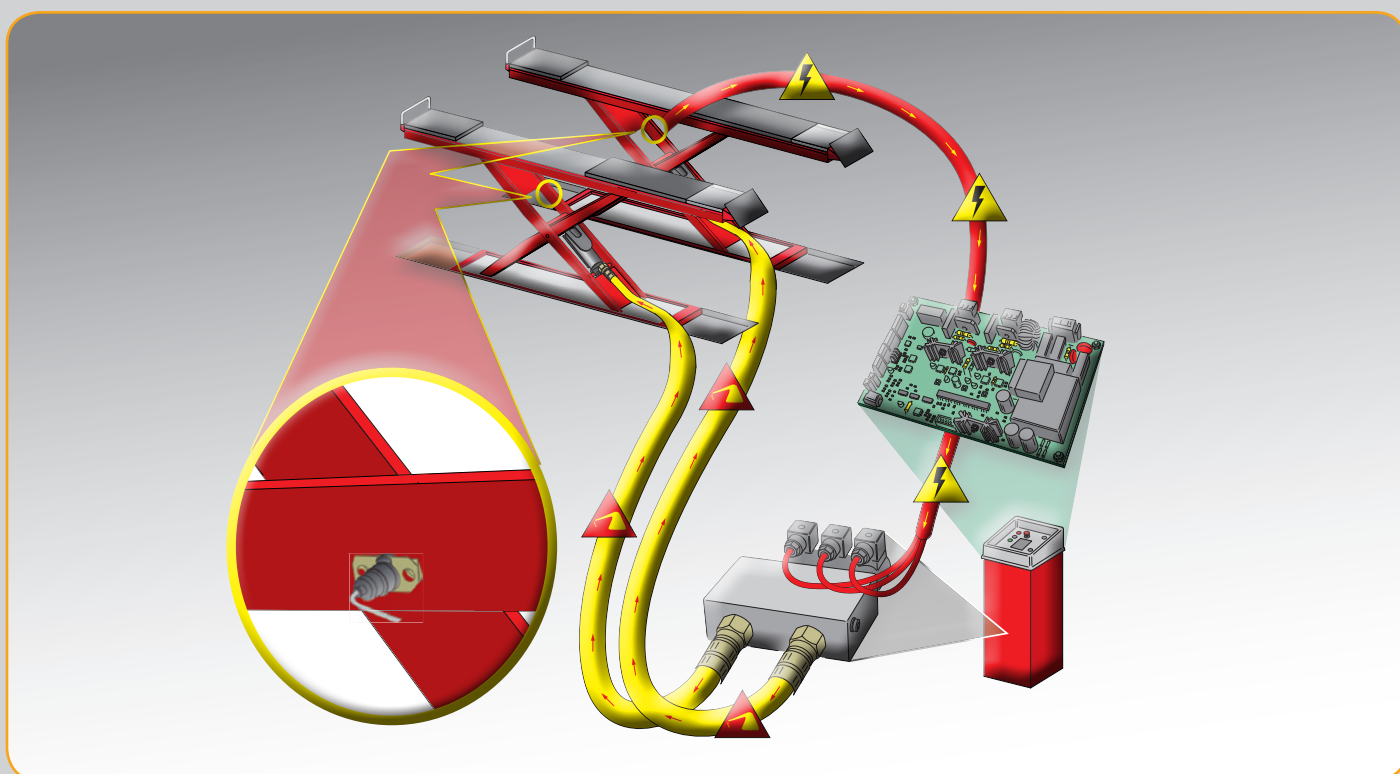

- EN** — • The runways are kept correctly aligned by a **closed loop electrohydraulic circuit**.
 • Proportional hydraulic control ensures that, throughout the entire vertical travel, the runways move smoothly in **perfect alignment** and with no oscillation.
- IT** — • L'allineamento delle pedane è garantito da un **circuito elettroidraulico in anello chiuso**.
 • Grazie alla gestione proporzionale dell'idraulica l'**allineamento delle pedane** si presenta privo di oscillazioni e costante durante tutta la corsa di sollevamento.
- DE** — • Die Ausrichtung der Schienen wird durch eine **elektrohydraulische Anlage mit geschlossenem Regelkreis gewährleistet**.
 • Dank der Proportionalsteuerung der Hydraulik ist die **Schienausrichtung während** der gesamten Hubfahrt schwingungsfrei und konstant.

PSR 50

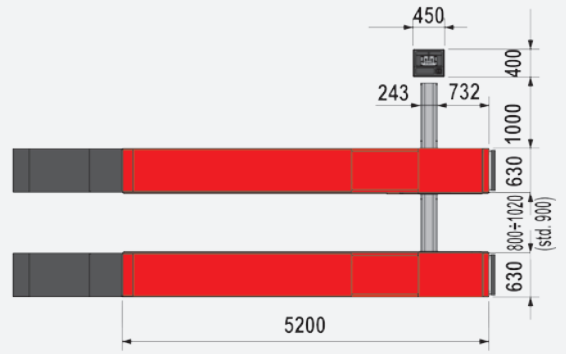
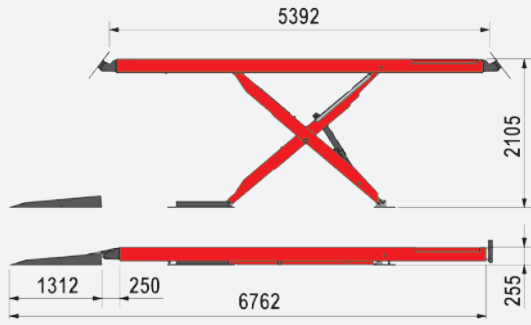

PSR 50 CT

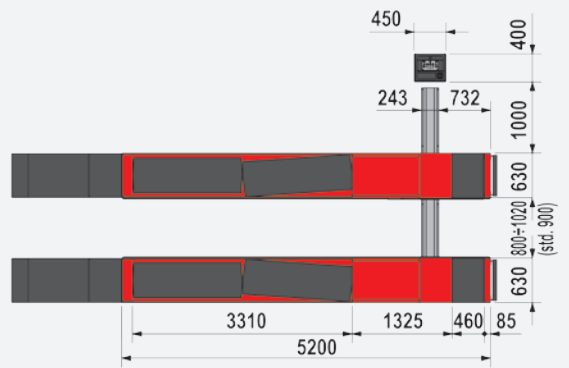
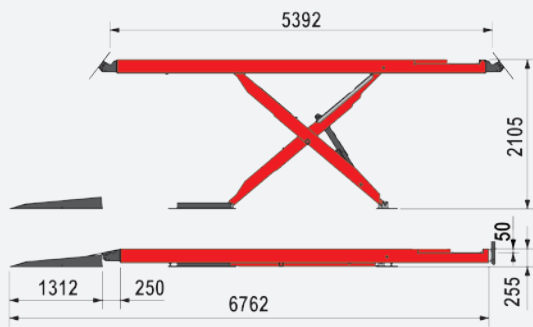

PSR 50 CT PT

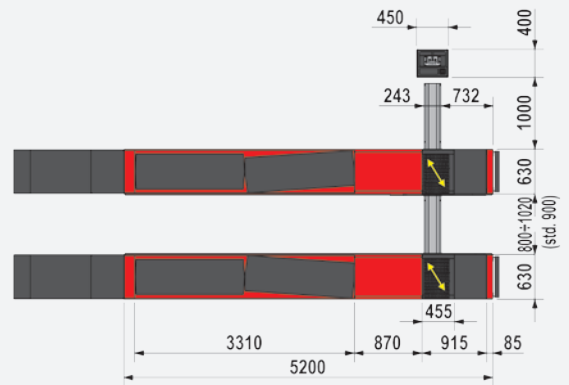
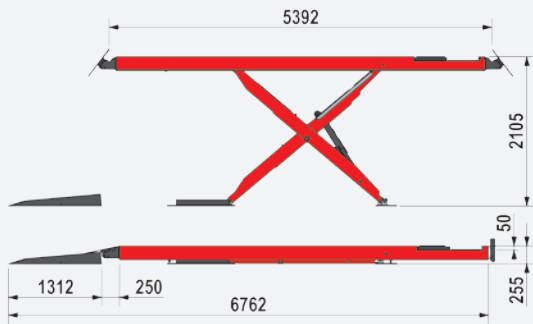

PSR 50 PT

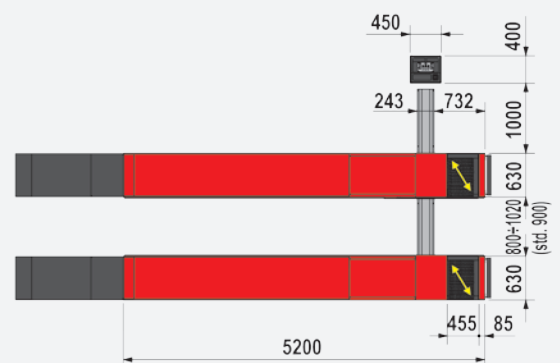
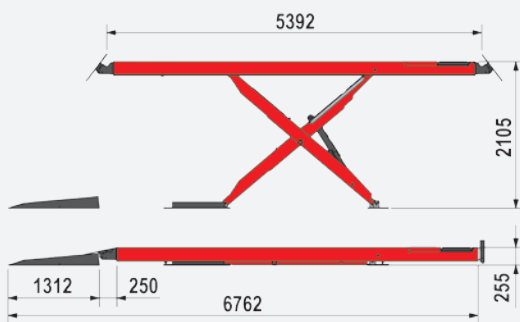

PSR 50 LT

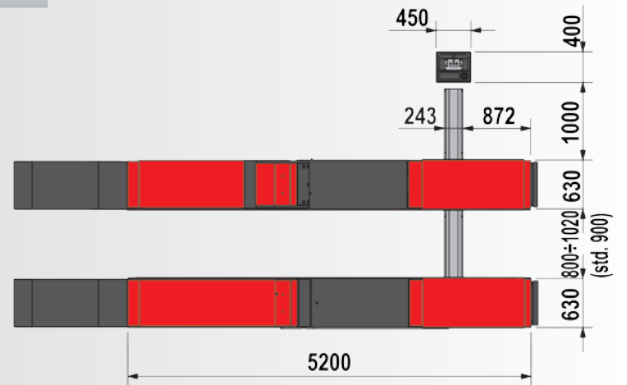
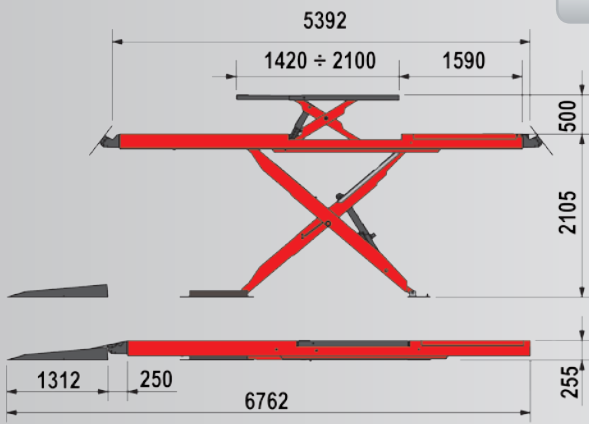

PSR 50 CT LT

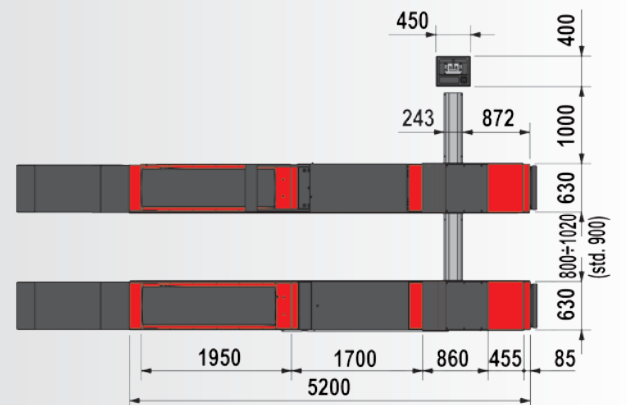
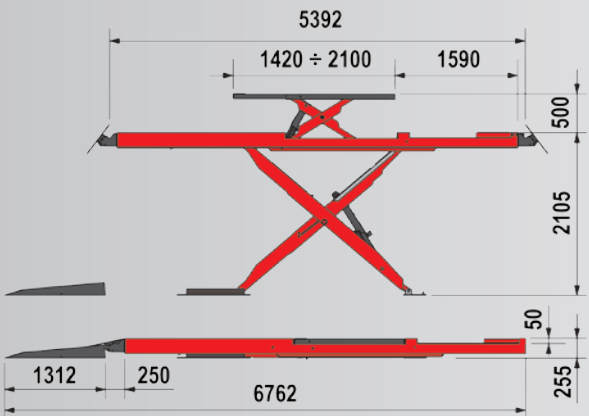

PSR 50 LT PT

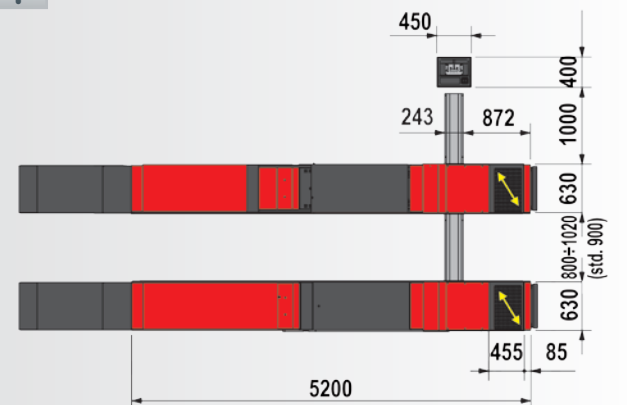
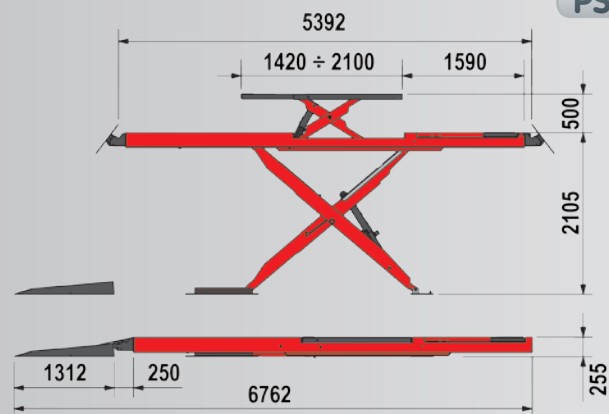

PSR 50 CT LT PT

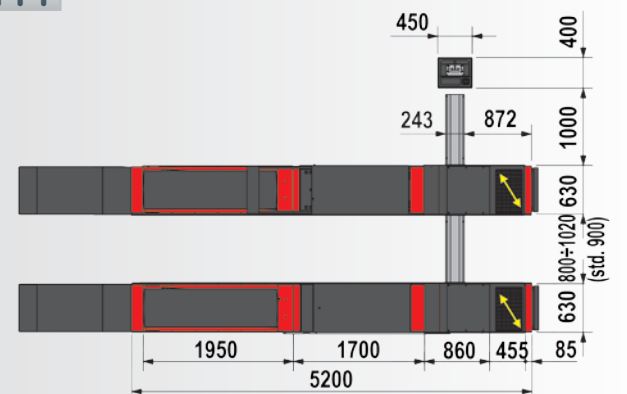
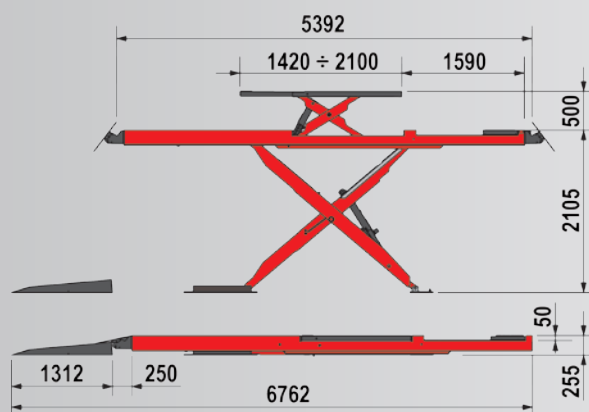

PSR 43

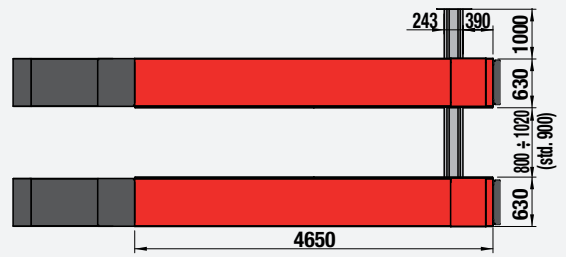
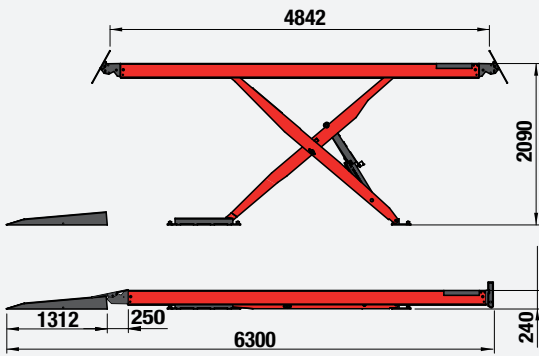

PSR 43 CT

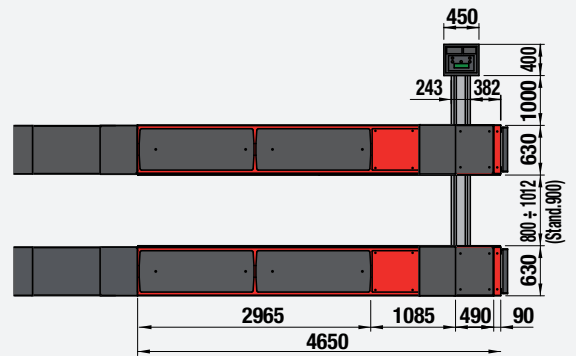
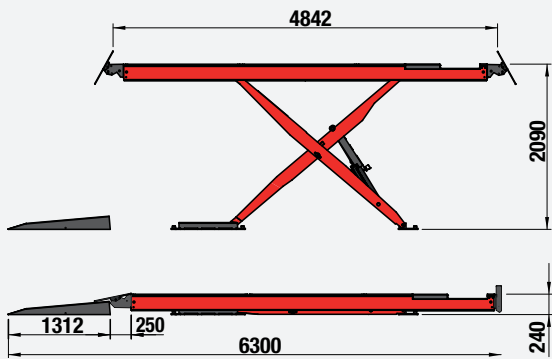

PSR 43 PT

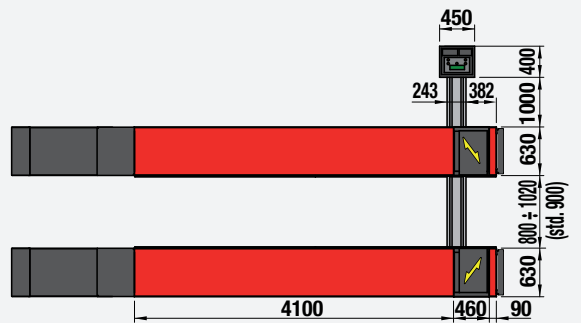
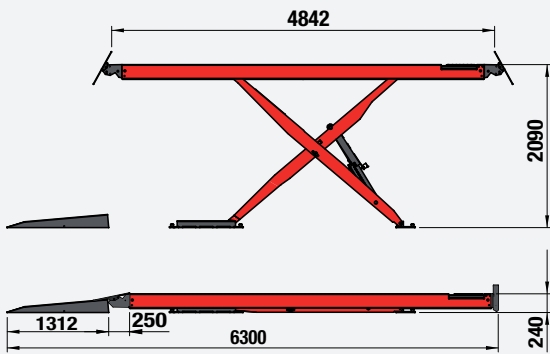

PSR 43 CT LT

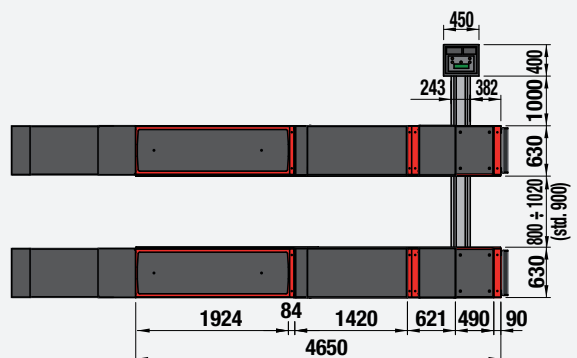
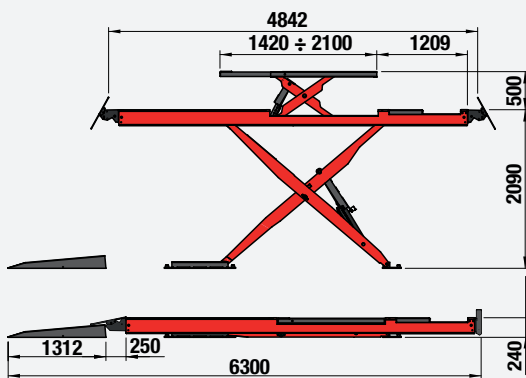

• CODE • CODICE • BEST.- NR.	• DESCRIPTION • DESCRIZIONE • BESCHREIBUNG
8-42300048	Floor ramp kit - Kit rampe a terra - Satz Bodenrampen
8-42300054	Flap wheel stop - Kit fermaruota (flap) - Satz hintere Radfeststell-Flaps
8-42300055	Front wheel block kit - Kit fermaruota anteriore - Satz Radfeststeller vorn
8-42300056	Floor installation kit - Kit installazione a pavimento - Satz für ebenerdige Installation
8-42300057	Pit installation kit - Kit installazione ad incasso - Grube-Einbausatz
8-42300058	Kit of spacers to reduce the size of the turntable housing to 460 mm - Kit de pièces d'écartement pour réduire la taille du boîtier plateau tournant de 460 mm - Satz Stopfen zur Verkleinerung der Drehteller- Vertiefung auf 460 mm

EN → **Recommended accessories** IT → **Accessori consigliati** DE → **Empfohlenes Zubehör**

• CODE • CODICE • BEST.- NR.	• DESCRIPTION • DESCRIZIONE • BESCHREIBUNG
8-42300030	Extra large floor ramp kit - Kit rampe a terra extra lunghe - Satz extra lange Bodenrampen
8-42300060	Lighting kit - Kit illuminazione - Beleuchtungs-Bausatz
8-42300063	Hang ramp kit - Kit rampe appese - Satz aufgehängte Rampen
8-42300081	1000 mm protection kit for pipes - Kit protezione tubi da 1000 mm - Satz Schlauchverlängerung, 1mt
8-42300082	Angle protections kit for pipes - Kit angolo protezione tubi - Satz Winkelstück-Schlauchverlängerung
8-42300083	Frame set for pit installation (2 pieces) - Set telaio per incasso (2 pezzi) - Satz Rahmen für Unterflur-Bauarbeiten (2Stück)
8-42300084	Runway edges kit - Bordi pedane versione a pavimento - Schienenleisten
8-42300026	Pair of beams for all-terrain vehicles - Coppia traverse per fuoristrada - Querträger für Geländewagen
8-42300064	Pipe extension kit L = 4mt - Kit prolunga tubi L = 4mt - Satz Schlauchverlängerung, L = 4mt (PSR 50)
8-42300080	Pipe extension kit L = 2mt - Kit prolunga tubi L = 2mt - Satz Schlauchverlängerung, L = 2mt (PSR 50)
8-42300095	Pipe extension kit L = 4mt - Kit prolunga tubi L = 4mt - Satz Schlauchverlängerung, L = 4mt (PSR 43)
8-42300100	Pipe extension kit L = 2mt - Kit prolunga tubi L = 2mt - Satz Schlauchverlängerung, L = 2mt (PSR 43)
8-42100015	JB-22 Pneumo-hydraulic cross beam 2200 kg - Traversa pneumoidraulica 2200 Kg - Pneumatisch-hydraulischer Querträger (2200 kg)
8-42100123	Customising cross beam kit JB - 22 - Kit personalizzazione traversa JB-22 - Personalisierung-Satz für JB-22

EN → **Technical Data** IT → **Dati Tecnici** DE → **Technische Daten**

	PSR 50	PSR 43		
	5000 kg	4300 kg		95"
	3500 kg			8"
	255 mm	240 mm		230/400 - 3Ph - 50Hz
	2105 mm	2090 mm		3kW
	5200 mm	4650 mm		/15 - Standard RAL 3002

The manufacturer reserves the right to modify the features of its products at any time. Fotografie, caratteristiche ed i dati tecnici non sono vincolanti, possono subire modifiche senza preavviso. Die Fotografien, die angegebenen Eigenschaften und die technischen Daten sind nicht verbindlich und können ohne Vorankündigung geändert werden.



Nexion Engineering S.r.l.
 via Modena, 34 - 42015 Correggio RE - Italy
 Tel. +39 0522 693640 - Fax +39 0522 642882 www.sice.it - sice@sice.it

