

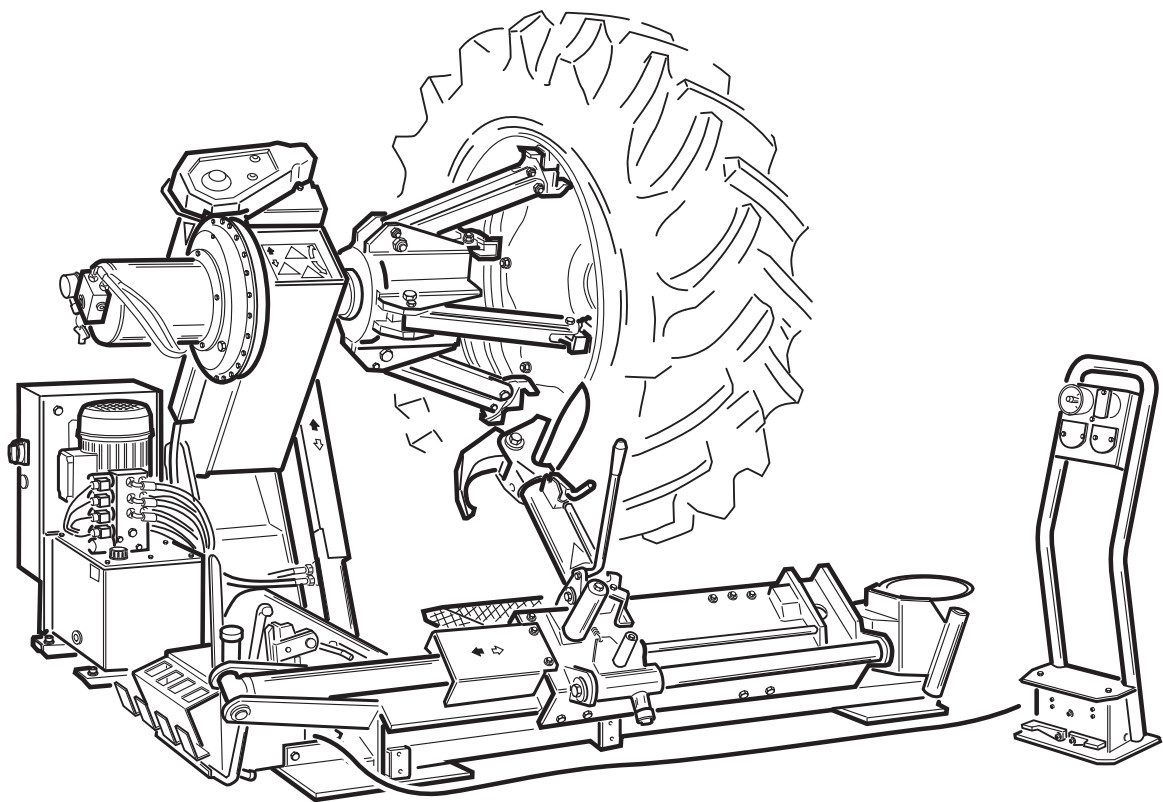

Automotive Equipment

UNIVERSAL TRUCK TYRE CHANGER

TECO 55A



INSTRUCTION MANUAL

3



MADE IN ITALY
CORREGGIO - R.E.



**DICHIARAZIONE CE DI CONFORMITA'
CE DECLARATION OF CONFORMITY
DECLARATION CE DE CONFORMITE
CE -KONFORMITÄTSEKTLÄRUNG
DECLARACION CE DE CONFORMIDAD**

TECO S.R.L.
via Pio La Torre, 10 - 42015 Correggio (RE) ITALY

DICHIARA CHE IL PRODOTTO A CUI QUESTO MANUALE FA RIFERIMENTO, UTILIZZATO UNICAMENTE CON ACCESSORI ORIGINALI E IN OSSERVANZA ALLE INDICAZIONI CONTENUTE NEL PRESENTE MANUALE, E' CONFORME ALLE SEGUENTI DIRETTIVE E DOCUMENTI NORMATIVI:

Direttive applicabili: 98/37/CE, 2006/95/CE; 2004/108/CE; 86/217/CEE; 87/404/CEE (modificata con la direttiva 93/68/CEE).

Normative applicabili: EN ISO 12100-1; EN ISO 12100-2; EN 60204-1.

DECLARES THAT THE PRODUCT TO WHICH THIS MANUAL REFERS, USED ONLY WITH ORIGINAL ACCESSORIES AND IN ACCORDANCE WITH THE INSTRUCTIONS IN THIS MANUAL, IS COMPLIANT WITH THE FOLLOWING DIRECTIVES AND STANDARDS:

Applicable directives: 98/37/CE, 2006/95/CE; 2004/108/CE; 86/217/CEE; 87/404/CEE (amended with directive 93/68/CEE).

Applicable standards: EN ISO 12100-1; EN ISO 12100-2; EN 60204-1.

DECLARE QUE LE PRODUIT AUQUEL CE MANUEL SE REFERE, UTILISE UNIQUEMENT AVEC DES ACCESSOIRES D'ORIGINE ET EN SUIVANT LES INDICATIONS DONNEES DANS CE MANUEL, EST CONFORME AUX DIRECTIVES ET DOCUMENTS SUIVANTS :

Directives applicables: 98/37/CE, 2006/95/CE; 2004/108/CE; 86/217/CEE; 87/404/CEE (modifiée avec la directive 93/68/CEE).

Normes applicables: EN ISO 12100-1; EN ISO 12100-2; EN 60204-1.

ERKLÄRT HIERMIT, DASS DAS PRODUKT, AUF DAS SICH DIE VORLIEGENDE BETRIEBSANLEITUNG BEZIEHT, BEI VERWENDUNG AUSSCHLIESSLICH MIT ORIGINAL-ZUBEHÖRTEILEN UND GEMÄSS DEN ANWEISUNGEN IM VORLIEGENDEN HANDBUCH DEN VORGABEN FOLGENDER RICHTLINIEN UND NORMEN ENTSPRICHT:

Anwendbare Richtlinien: 98/37/CE, 2006/95/CE; 2004/108/CE; 86/217/EEG; 87/404/EEG (mit der Richtlinie 93/68/EEG modifiziert).

Anwendbare Normen: EN ISO 12100-1; EN ISO 12100-2; EN 60204-1.

DECLARA QUE EL PRODUCTO AL QUE SE REFIERE ESTE MANUAL, UTILIZADO ÚNICAMENTE CON ACCESORIOS ORIGINALES Y CON OBSERVANCIA DE LAS INDICACIONES DEL PRESENTE MANUAL, ES CONFORME CON LO DISPUESTO EN LAS SIGUIENTES DIRECTIVAS Y DOCUMENTOS NORMATIVOS:

Directivas aplicables: 98/37/CE, 2006/95/CE; 2004/108/CE; 86/217/CEE; 87/404/CEE (modificada segun la directiva 93/68/CEE).

Normativas aplicables: EN ISO 12100-1; EN ISO 12100-2; EN 60204-1.

Correggio, 18 - 03 - 2008

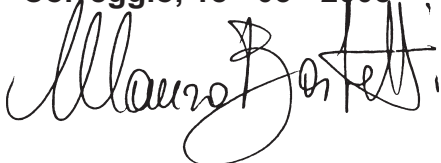

TECO srl
Barbetti Ing. Mauro

**SMONTAGOMME PER RUOTE CAMION UNIVERSALE- UNIVERSAL TRUCK
TYRE CHANGER - DEMONTE-PNEUS UNIVERSEL POUR PL - UNIVERSAL
LKW-REIFENMONTIERMASCHINE - DESMONTADORA DE NEUMATICOS
UNIVERSAL PARA CAMIONES**



Il modello della presente dichiarazione è conforme a quanto previsto nella EN 45014
The form of this statement conforms to EN 45014 specifications

Le modèle de la présente déclaration est conforme à ce qui est prévu par la Norme
EN 45014

Das Formular dieser Bestätigung entspricht den Bestimmungen der EN 45014

El modelo de la presente declaración es conforme a cuanto está previsto en las
especificaciones EN 45014

INDEX

- 1. GENERAL INFORMATION 30
- 2. TECHNICAL DATA 30
- 3. GENERAL SAFETY REGULATIONS 30
- 4. SAFETY DEVICES 31
- 5. TRANSPORT 31
- 6. INSTALLATION 31
 - 6.1 Installation place 31
 - 6.2 Unpacking 32
 - 6.3 Workplace requirements 32
 - 6.4 Electric hook up 32
- 7. IDENTIFYING WARNING SIGNALS 33
- 8. FUNCTIONAL PARTS LAYOUT 34
- 9. IDENTIFICATION OF CONTROLS 35
- 10. WORKING POSITION 36
- 11. CORRECT OPERATION CHECKS 36
- 12. OPERATION 37
 - 12.1 Locking the wheel 37
 - 12.2 Tubeless and Supersingle wheels 38
 - 12.3 Tubed wheels 43
 - 12.4 Wheels with split ring 46
- 13. OPTIONAL ACCESSORIES 50
- 14. MOVING THE MACHINE 50
- 15. STORING 51
- 16. SCRAPPING A MACHINE 51
- 17. FIRE-FIGHTING 52
- 18. DATA ON SERIAL PLATE 52
- 19. ROUTINE MAINTENANCE 52
- 20. TROUBLE SHOOTING 53

1. GENERAL INFORMATION

The TECO 55A tyre changer has been specifically designed to demount and mount truck, bus, tractors and earth moving vehicles tyres, with rims from 14" to 46" (56" with SE extension) and a maximum 2300 mm diameter.

Any other use is improper and therefore not authorized.

Before beginning any kind of work on or with this machine, carefully read and understand the contents of these operating instructions.

TECO srl shall not liable for any injury to persons or damage to things caused by improper use of this machine.

KEEP THIS MANUAL NEAR THE MACHINE AND CONSULT IT AS NEEDED DURING OPERATIONS.

2. TECHNICAL DATA

Pump motor	1,5 kW
Gear-box motor	1,3 - 1,85 kW
Handles rim from - to	14" - 46" (56" with SE)
Max. wheel diameter	2300 mm (90")
Max. wheel width	1065 mm (42")
Max. wheel weight	1600 kg
Weight (with standard accessories)	762 kg
Acoustic pressure level (at work)	LpA < 70 dB(A)

3. GENERAL SAFETY REGULATIONS

Operators who work with this machine must be qualified and authorized.

To be considered qualified, an operator must understand the written instructions given by the manufacturer, be trained and be familiar with the regulations governing labour safety.

Operators must not make use of drugs or alcohol which could alter their faculties.

It is, however, essential to:

- Know how to read and understand the descriptions.
- Know the performances and characteristics of this machine.
- Keep unauthorized persons away from the operating zone.
- Make sure that the installation has been made in compliance with all the pertinent regulations and standards in force.
- Make sure that all the operators have been sufficiently trained, that they know how to use the equipment in a correct and safe way and that there is adequate supervision.
- Never touch the electrical equipment or power lines unless the power has been previously turned off.
- Carefully read this manual and learn how to correctly and safely use the machine.
- Always keep this manual ready to hand in an easily accessible place and consult it when necessary.



WARNING!

Unauthorized variations or modifications to the machine shall relieve the manufacturer from all liability for any deriving damages or accidents.

In particular, removal or tampering with the safety devices represents a violation of the Labour Safety regulations.

4. SAFETY DEVICES

The TECO 55A tyre changer has a number of safety devices designed to guarantee the utmost operator safety:

1. Check valve on the spindle opening hydraulic line (inside the swivel connector, see fig. B/1). This prevents the wheel from falling from the spindle if the hydraulic line is accidentally broken.
2. Pilot operated dual seal check valve (see Fig. B/2). This prevents the spindle carrier arm from dropping if the hydraulic circuit accidentally breaks.
3. Pump motor overload cut-out (inside the electric enclosure). This cuts in if the motor overheats to prevent it from burning out.
4. Mechanical tool arm tip lock device (See Fig. B/3). Prevents the arm from being moved to its "non-working position" if the tool has been removed.

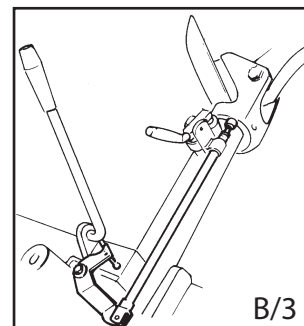
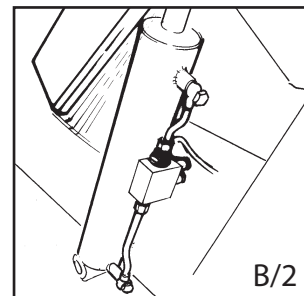
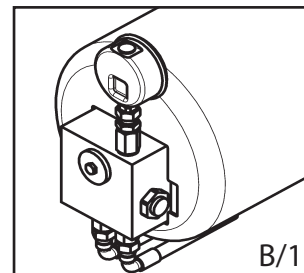

CAUTION: Removing or tampering with the safety devices is in violation of European safety regulations and releases the manufacturer from all liability for damage caused by or related to such actions.

5. TRANSPORT

The machine is delivered in a wooden box with pallet.

Shipping weight is 892 kg.

The machine must be handled with a fork-lift truck with the forks positioned as shown in the figure A/2.

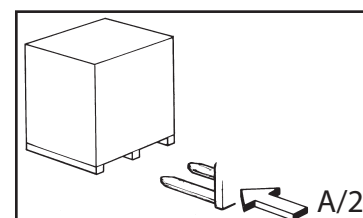

6. INSTALLATION

6.1 INSTALLATION PLACE

Choose the place the machine is to be installed in compliance with current work place safety regulations.

The floor should not be broken or uneven so that the machine will be stable.

If the installation is outdoors, it must be protected by some kind of roofing against rain.

The following work environment conditions are applicable:

Relative humidity: from 30-95% without condensation;

Temperature: from 0-55° C.



WARNING!
The machine must not be operated in explosive environments.

6.2 UNPACKING

Once the packing material has been removed, check the machine visually for any signs of damage.

Keep the packing materials out of the reach of children as they can be a source of danger.

N.B.: Keep the packing for possible future transport.

6.3 INSTALLATION PLACE

Maximum machine space requirements are 2200 x 1640 mm with a minimum distance from walls as shown in the diagram B/4.



CAUTION! These measurements are also the tyre changers working range.

Persons other than specially trained and authorized operators are expressly forbidden to enter this area.

Position the tyre changer lifting it with the specific bracket (1, Fig. A) with the tool carrier arm (2, Fig. A) lowered all the way, the spindle (3, Fig. A) closed and the tool carrier slide (4, Fig. A) at its stop close to the arm.

If you work with wheels weighing less than 1000 kg, the machine need not be anchored to the floor. In any case, the floor must be smooth and allow the platform rollers to move without hindrance.

FIXING THE MACHINE

The machine should be fixed to the floor when the wheels handled weigh more than 1000 kg.

To anchor the machine to the floor use 3 Ø 16 metal expanding bolts.

Drill holes in the floor at the fixing points in the machine's feet as indicated by the arrows in Figure B/5.

Insert the expansion bolts in the drilled holes and tighten the screws all the way.

6.4 ELECTRIC HOOK UP

Before making any electric hook up, check to be certain that the mains voltage corresponds to that stamped on the voltage tag (attached to the cord near the tyre changer's plug).

It is absolutely essential that :

- the system is equipped with a good grounding circuit.
- The machine is connected to a power supply line circuit breaker set for 30 mA.
- The power socket take is adequately protected against overcurrents with fuses or circuit-breakers with rated values as shown in the table below.

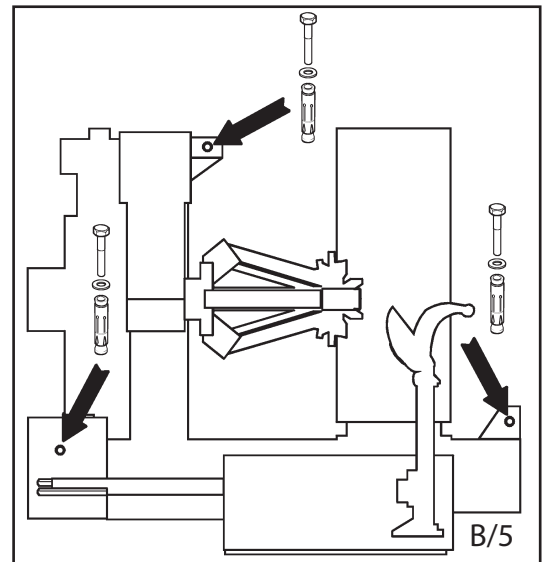
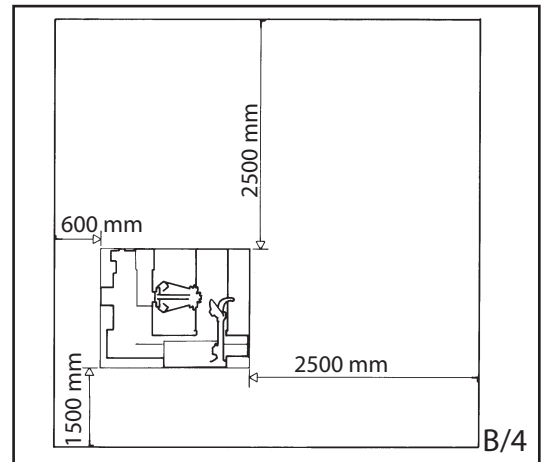
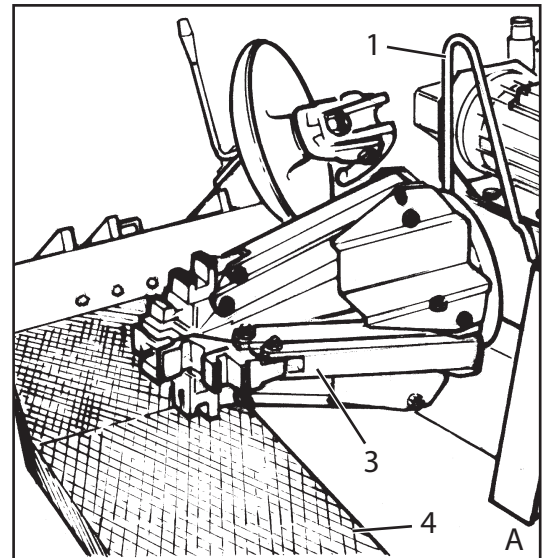

Note the required power draw as highlighted on the data plate fixed to the tyre changer.
 Check to make sure the shop electric wiring circuit is dimensioned sufficiently to carry this.

POWER SUPPLY	RATED CURRENT	
	FUSE	SWITCH
230V - 3Ph - 50/60Hz	32A AM	32A
400V - 3Ph - 50/60Hz	16A AM	25A



Work on the electric system, even if minor, must be done exclusively by professionally qualified personnel. Manufacturer shall not be liable for any injury to persons or damage to property caused by failure to comply with these regulations and can cancel warranty coverage.

TURNING DIRECTION CHECKS

Connect the machine to the mains, switch "ON" (5, fig. A) and check that the hydraulic power pack motor rotation corresponds to the indicating arrow (6, fig. A).
 Otherwise, have an electrician switch two wires in the power supply plug.

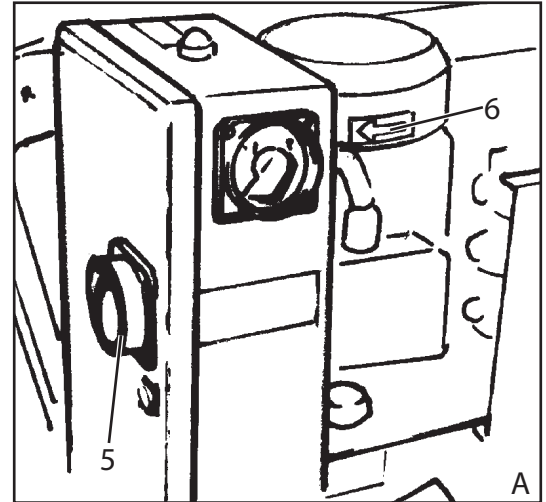

7. IDENTIFYING WARNING SIGNALS



Hand-crushing hazard between turntable jaws.



Crushing hazard between turntable arm and tyre changer body.



Mind to the tool-holding arm during tilting or opening.



Crushing hazard between turntable and tool.



Feet-crushing hazard during turntable turning or opening



Wheel-faling hazard



Do not leave working place if the wheel is still mounted on the turntable.



Danger:electric voltage presence.



WARNING:
Unreadable and missing warning labels must be replaced immediately.
Do not use the tyre changer if one or more labels are missing.
Do not add any object that could prevent the operator from seeing the labels.
Use the code in this table to order labels you need.

8. FUNCTIONAL PARTS LAYOUT

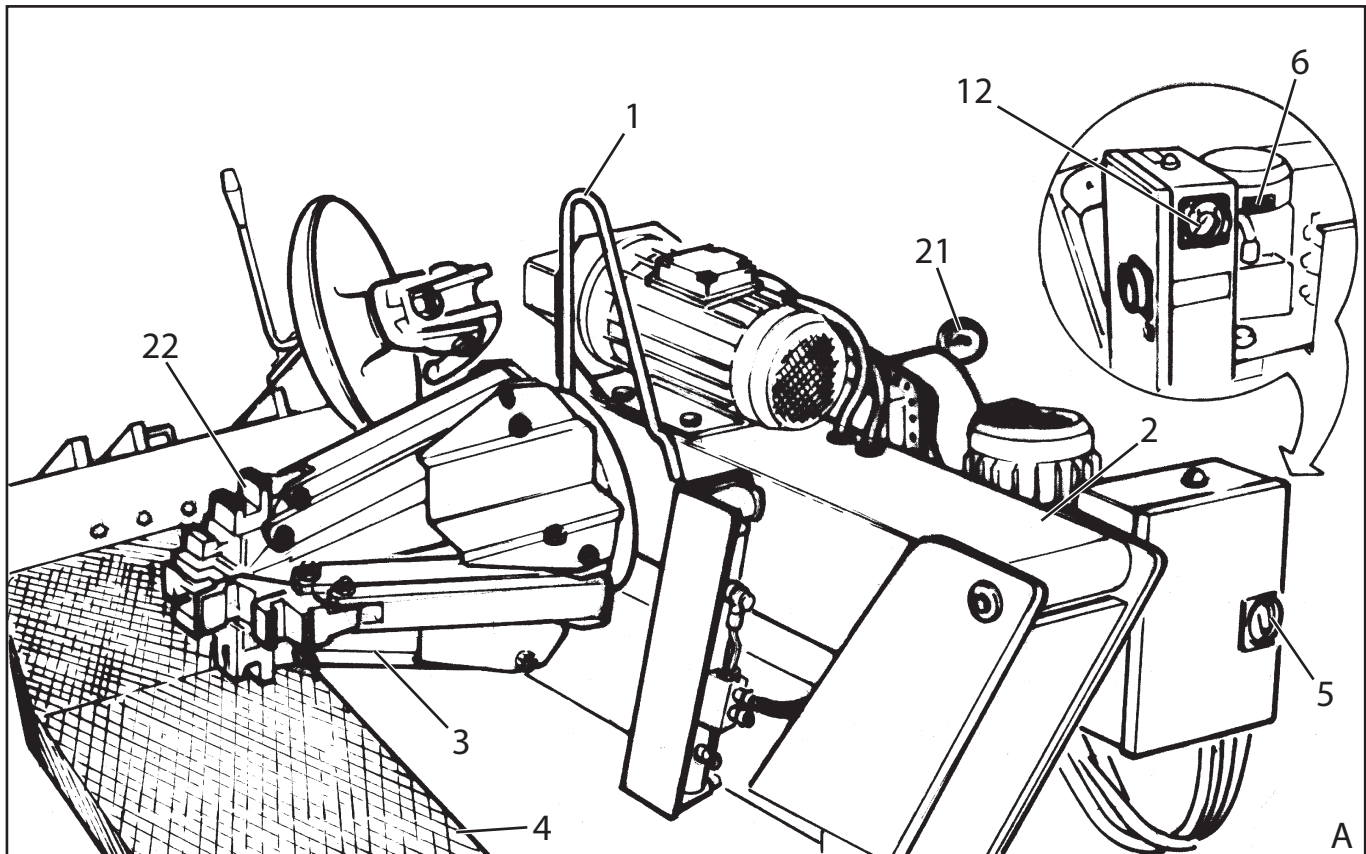

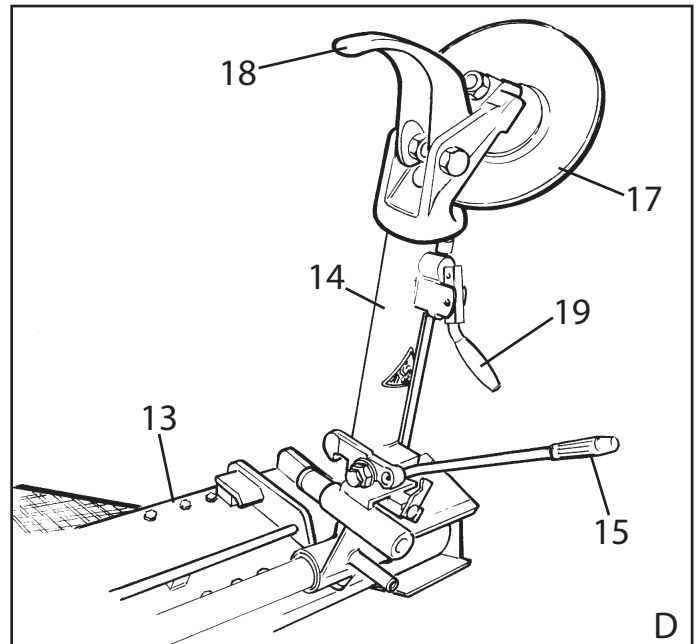
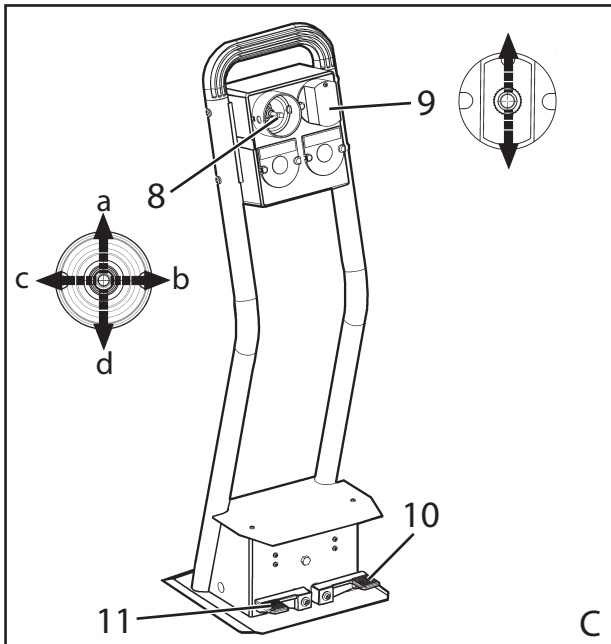

- 1 - Lifting bracket
- 2 - Self-centering chuck holding arm
- 3 - Self-centering chuck
- 4 - Sliding table
- 5 - Main switch
- 8 - Handler
- 9 - Switch
- 10 - Chuck clockwise rotation pedal
- 11 - Chuck anticlockwise rotation pedal

- 12 - 2nd-speed switch
- 13 - Carriage
- 14 - Tool holding arm
- 15 - Arm lever
- 17 - Bead breaking disk
- 18 - Tool
- 19 - Tool handle
- 21 - Manometer
- 22 - Jaw

9. IDENTIFYING CONTROLS

The mobile control centre (fig. C) enables the operator to work at any position around the machine. On this mobile control centre the following controls are located:

-The lever (8, fig. C) which in position a lifts the chuck arm and in position b lowers it; in position c moves the tool holder arm and the sliding table towards the self-centering chuck and in position d moves them away.

Note: in order to memorise this operation, there is a hole in the lever guard corresponding to position c.

-The chuck switch (9, fig. C) when moved upwards, opens the arms of the self-centering chuck (LOCKING), and when moved down, closes the arm of the self-centering chuck (UN-LOCKING).

- The clockwise rotation pedal (10, fig. C): pressed to turn the chuck clockwise.

- The anticlockwise rotation pedal (11, fig. C): pressed to turn the chuck anticlockwise.

NOTE: all the controls are very sensitive and small movements of the machine can be done with precision.

The TECO 55A tyre changer also has:

Lever (15, Fig. D) to tip the tool carrier arm (14, Fig. D) from its work to its non-working position and vice-versa.

Handle (19, Fig. D) that permits alternative use of the bead-breaking disk (17, Fig. D) or the hooked tool (18, Fig. D).

10. WORKING POSITION

The diagram B/8 illustrates the various working positions (a, b, c, d) referred to in the following pages describing how to use the tyre changer.

Use of these positions ensures greater precision, speed and safety for those using the machine.

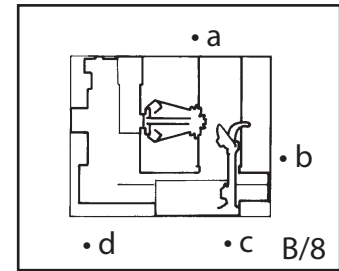

11. CORRECT OPERATION CHECKS

Before using the tyre changer, a number of checks should be made to ensure it works correctly.



CAUTION! The operations described here should be done with the tool carrier arm in its non-working position. First use lever (15, Fig. C) to tip the arm to this position.



CAUTION!
Do not move your face close to the tool carrier arm when you release it to tip it as needed.

- 1) move the joystick (8, Fig. C) up (a): the spindle carrier arm (2, Fig. A) should lift;
move the joystick down (b): the arm should lower.
move the joystick towards the left (c): the tool carriage and the mobile platform (13, Fig. D) should move towards the spindle (3, Fig. A);
move the joystick towards the right (d) the carriage and platform should move away from the spindle.



DANGER!
When the spindle carrier arm is lowered, there is always a potential for crushing anything in its movement range. Always work from the position given in the instructions keep well out of the working of the various moving arms.

- 2) turn switch lever (9, Fig. C) towards the top: the spindle arms (3, Fig. A) should open;
move the lever down and the spindle arms should close.



DANGER!

When the spindle arms open or closed, there is always a potential for crushing anything in their movement range. Always work from the position given in the instructions keep well out of the spindle's working range.

- 3) depress the pedal (10, Fig. C): the spindle (3, Fig. A) should turn clockwise;
depress the pedal (11, Fig. C): the spindle should turn anticlockwise.

- 4) Check to be certain the hydraulic circuit is working correctly:
 - move switch lever (9, Fig. C) towards the top until the spindle arms are fully extended.
 - hold the switch lever in this position (top) and check if the pressure shown on the gauge on the swivel fitting is 130 bar \pm 5%.

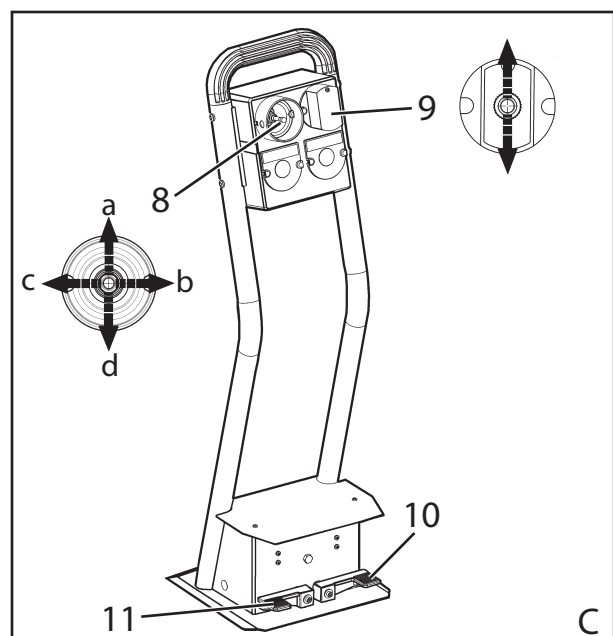



If the pressure value is not within the above indicate range see the "MAINTENANCE" of this manual to solve this problem.
 If the pressure shown in the manometer, is still not within this range, DO NOT USE the tyre changer and call your nearest TECO Assistance Centre.



DANGER! During all operations, keep hands and other parts of the body as far as possible from moving parts of the machine.
 Necklaces, bracelets and too large clothes, can be dangerous for the operator.

12. OPERATION

12.1 LOCKING THE WHEEL



WARNING!
 In locking the wheel, make sure that clamps are properly positioned on the rim, so as to prevent the tyre from falling.

1) Take the mobile control unit to work position B.

2) Pull the tool-holder arm (14, fig. D) into the upright position.

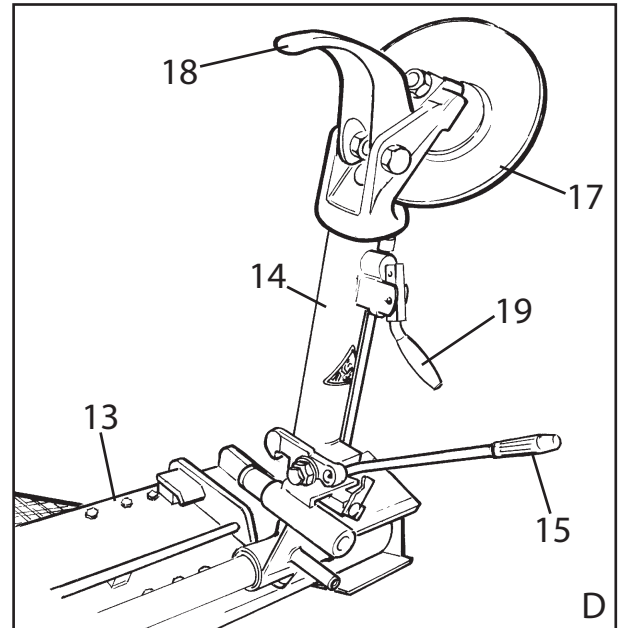

3) Operating from the mobile control centre, move the sliding table (13, fig. D) away from the self-centering chuck and place the wheel in vertical position on the sliding table.



DANGER!
 This operation can be extremely dangerous.
 Do it manually only if you are certain you can keep the wheel balanced.
 For large and heavy tyres an adequate lifting device must be used.

4) Continuing to operate from the mobile control centre, lift or lower the arm in order centre the self-centering chuck (3, fig. A) relative to the rim.

5) With the jaws (22, fig. A) in the closed position, move the wheel on the sliding table to the self-centering chuck. Operate the chuck switch (9, fig. C) to open the self-centering chuck and lock onto the inside wheel rim.

The most convenient locking position on the rim may be selected according to figs E/1 - E/2 - E/3 - E/4 - E/5 and E/6.

Always remember that the safest locking is on the central flange.

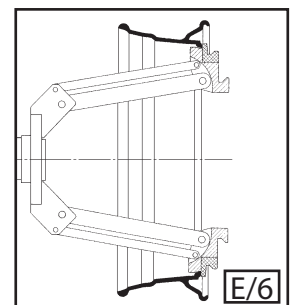
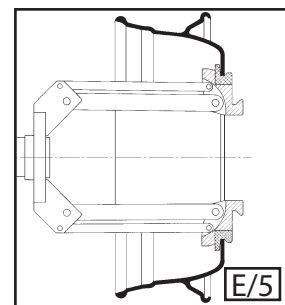
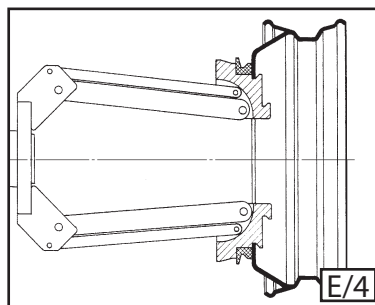
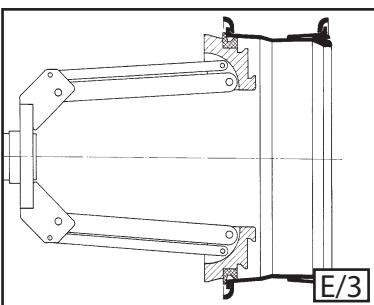
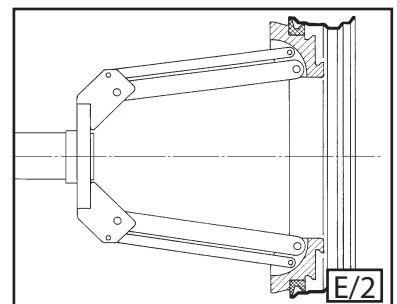
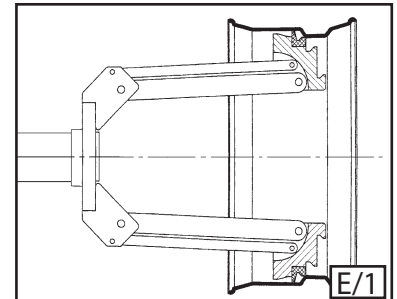

N.B. for rims with channel, clamp the wheel so that the channel is near the outside of the rim (fig. E/1).



DANGER!
Do not vary the work area with a wheel clamped on the tyre changer and lifted up from the floor.

LIGHT-ALLOY RIM LOCKING

The JAR clamps - especially designed for operating on light alloy rims without damaging them - is available upon request.

The JAR clamps are to be inserted (bayonet-like mounting) into the clamp support of the self-centering chuck (see fig. E/7).

Tighten screw 1, Fig. E/7 by hand to lock the JAR clamp.

The clamps are supplied with three different types of plastic insert (2, Fig. E/7), which must be used to suit the thickness of the rim flange.

Lock the rim as illustrated in fig. E/8.

The specially-made PAR alloy-rim pliers are also available.

CAUTION:

The spindle may "slip" during the various operating phases when the rims are locked on the central hole (especially with alloy wheels where JAR clamps are used).

This can be avoided by fitting a bolt into one of the wheel fixing holes (1, Fig. E/9) and locking it in place with the relative nut.

As the bolt is turned, it will rest on the clamp, carrying the rim with it and preventing this from slipping.

CLAMP EXTENSIONS

For rims with diameters over 46" without central hole flange, the wheel can be clamped with the SE extensions (optional).

Insert the clamp extension into the clamp support of the self-centering chuck arm (bayonet mounting) and lock it with the wing nut (see fig. E/10).

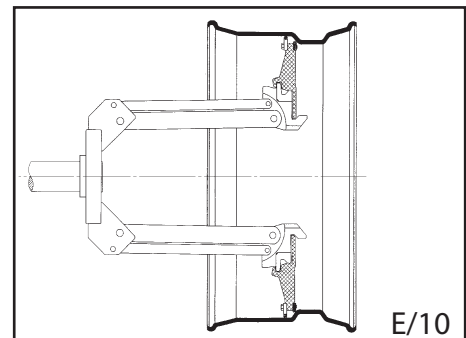
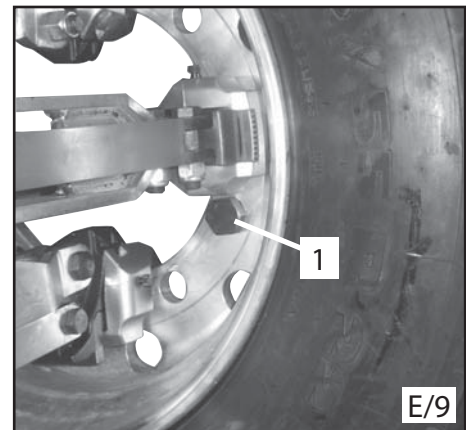
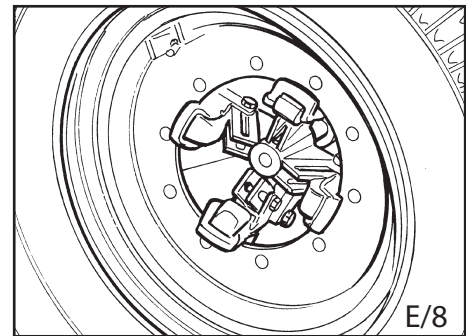
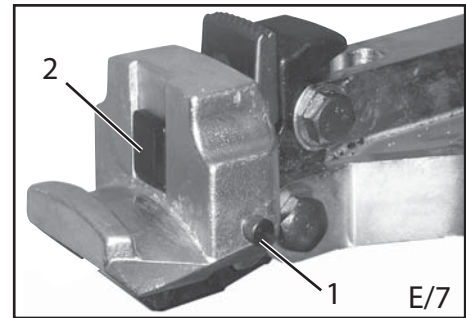

12.2 TUBELESS AND SUPERSINGLE WHEELS

BEAD BREAKING

- 1) Lock the wheel on the self-centering chuck, as previously described, and ensure that the tyre is deflated.
- 2) Take the mobile control unit to work position C.
- 3) Lower the tool-holder arm (14, fig. F) into its working position and allow it to lock.



DANGER!
Always check to be certain that the arm is corrected hooked to the carriage.

4) Operating from the mobile control centre, manoeuvre the wheel until the outside of the rim skims the bead-breaker disk (fig. F).



DANGER!
The bead breaker disk must NOT be pressed against the rim but against the tyre bead.

5) Rotate the wheel and at the same time, advance the bead-breaker plate with small forward movements following the profile of the rim, with the plate.

6) Continue until the first bead is fully detached.
To facilitate this operation, lubricate the bead and the edge of the rim with tyre lubricant whilst the wheel is rotated.



CAUTION!
To avoid all risk, lubricate the beads turning the wheel **CLOCKWISE** if you are working on the outside plane and **ANTICLOCKWISE** if working on the inside plane.

N.B.: Remember that the stronger the tyre's adherence to the rim, the slower must be the disk's penetration.

7) Bring the tool carrier arm (14, Fig. F) back from the edge of the rim. Release the hook, raise the arm to its non-working position, shift it and rehook it in its second work position (Fig. G).



DANGER!
Do not hold your hands on the tool when you bring it back to its work position.
Your hand(s) could be trapped between the tool and the wheel.

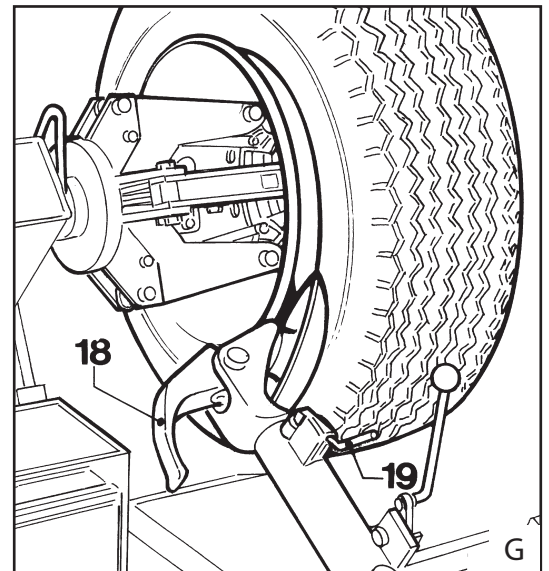
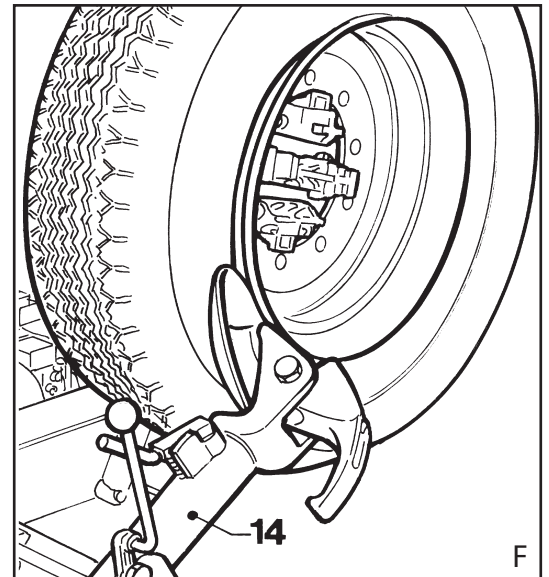

8) Push the double headed tool lever (19, fig. G) and turn the head 180° until it locks automatically.

9) Take the mobile control unit to work position D.

10) Repeat the operation previously described until the second bead is completely broken.

N.B.: During the bead breaking, the claw (18, fig.G) can be lowered so that it is out of the way.

DEMOUNTING

Tubeless tyres can be demounted in two ways:

a) If the tyre is not difficult to demount, once the beads have been loosened, use the bead disk to push against the inside plane of the tyre until both beads come off the rim (See Fig. H).

b) With Supersingle or very hard tyres the procedure described above cannot be used.

The hook tool will have to be used as follows:

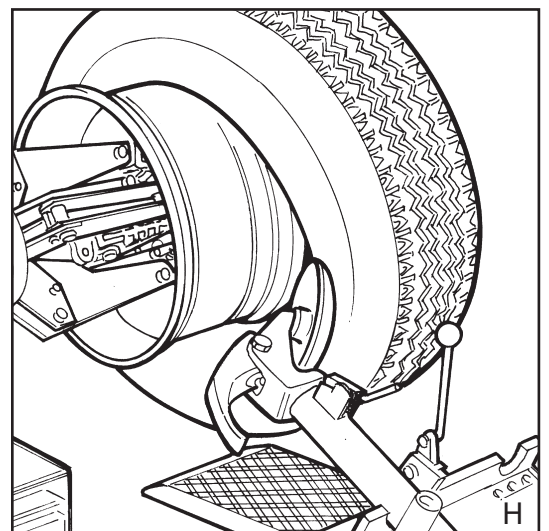

- 1) Transfer the tool carrier arm to the outside plane of the tyre.
- 2) Take the mobile control unit to work position C.
- 3) Rotate the wheel and at the same time move the hook tool forward inserting it between rim and bead until it is anchored to the bead (See Fig. I).
- 4) Move the rim 4-5 cm from the tool taking care that it does not unhook from the bead.
- 5) Move the hook tool towards the outside until the red reference dot is by the outside edge of the rim.
- 6) Take the mobile control unit to position B.
- 7) Insert lever LA (17, Fig. I) between rim and bead at the right of the tool.
- 8) Press down on the lever and lower the wheel to bring the edge of the rim about 5 cm from the hooked tool.
- 9) Turn the wheel anticlockwise pressing down on lever LA until the bead is completely off.
- 10) Move the tool carrier arm to its non-working position and then move it to the inside plane of the wheel.
- 11) Take the mobile control unit to work position D.
- 12) Turn the hook tool 180° and insert it between rim and bead (see Fig. L). Move it until the bead is by the edge of the rim (best to do this with the wheel turning).
- 13) Move the rim about 4-5 cm from the tool making sure the hook does not detach from the rim.
- 14) Take the mobile control unit to work position B.
- 15) Move the hook tool so that its red reference dot is about 3 cm inside the rim.
- 16) Insert lever LA (17, Fig. I) between rim and bead at the right of the tool.
- 17) Press down on the lever and lower the wheel to bring the edge of the rim about 5 cm from the hooked tool. Turn the wheel anticlockwise pressing down on lever LA until the tyre comes completely off the rim.

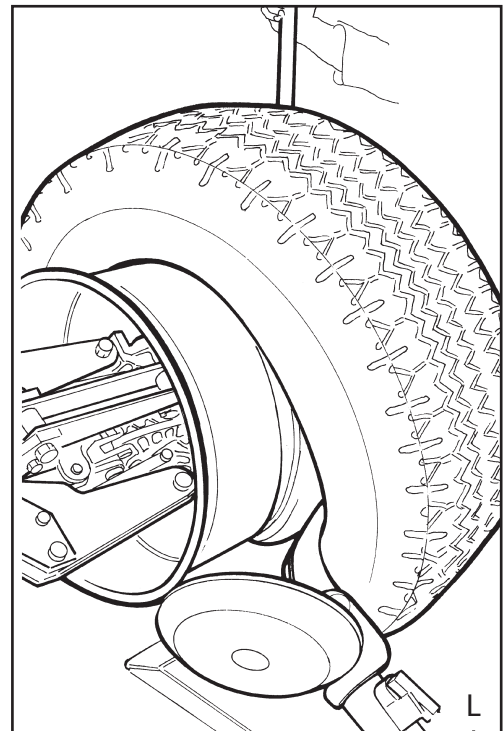
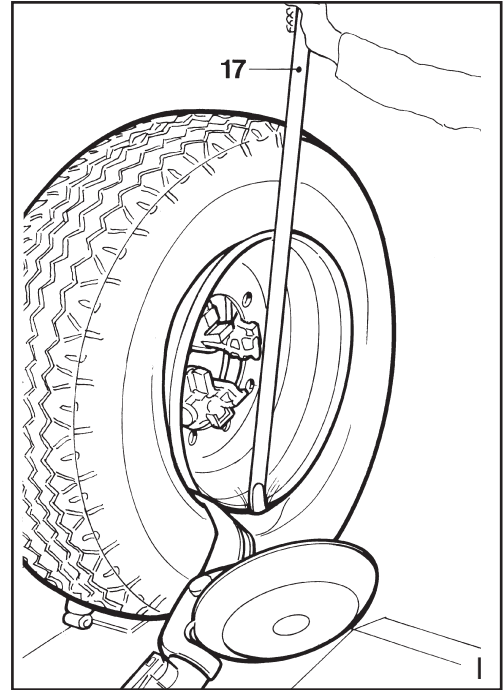

DANGER!
When the beads come off the rim, the tyre will fall.
Check to make sure there are no by-standers in the work area.

MOUNTING

Tubeless tyres can be mounted using either the bead breaker disk or the hook tool. If the tyre is not problematic, use the bead loosener disk. If the tyre is very rigid, the hook tool must be used.

TYRE MOUNTING WITH THE DISK

Follow these steps:

- 1) If the rim has been removed from the spindle, put it back on the spindle as described in the section on "CLAMPING THE WHEEL".
- 2) Lubricate both beads and the rim with tyre manufacturer recommended lubricant.
- 3) Attach the PC clip to the outside edge of the rim at the highest point (See Fig. M).



CAUTION!
Make sure the clip is firmly attached to the rim.

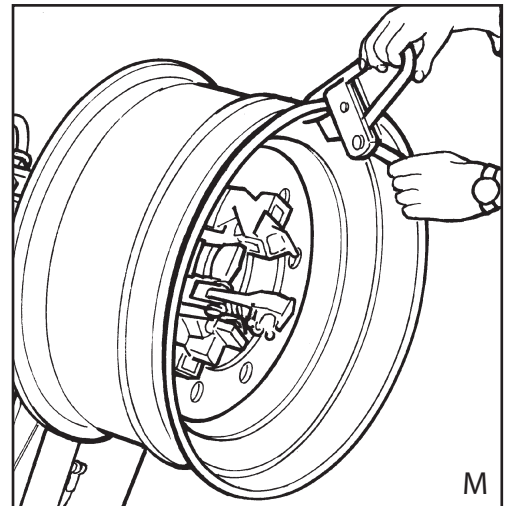

- 4) Take the mobile control unit to work position B.
- 5) Put the tyre on the platform and lower the spindle (make sure the clip is at the high point).
- 6) Lift the rim with the tyre hook to it and turn it anticlockwise about 15-20 cm. The tyre will be positioned tilted across the rim.
- 7) Take the mobile control unit to work position C.
- 8) Position the bead loosener disk against the second bead of the tyre and turn the spindle until the clip is at the low point (at 6 o'clock).
- 9) Move the disk away from the wheel.
- 10) Remove the clip and replace it at 6 o'clock outside the second bead (See Fig. N).

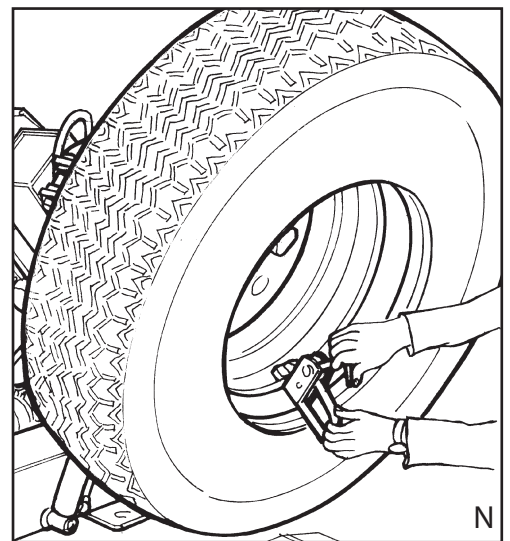

- 11) Turn the spindle clockwise 90° to bring the clip to 9 o'clock.
- 12) Move the disk forward until it is about 1-2 cm inside the edge of the rim. Begin to turn the spindle clockwise checking to make sure that, with a 90° turn, the second bead begins to slip into the centre well.
- 13) When the bead is fully mounted, move the tool away from the wheel, tip it to its non-working position and remove the clip.
- 14) Position the platform under the wheel, lower the spindle until the wheel rests on the platform.
- 15) Take the mobile control unit to work position B.
- 16) Close the arms of the spindle completely. Support the wheel to prevent it falling off.



DANGER!
This operation can be extremely dangerous.
Do it manually only if you are certain you can keep the wheel balanced.
For large and heavy tyres an adequate lifting device must be used.

- 17) Move the platform to remove the wheel from the spindle.
- 18) Remove the wheel.

NB: If the tyre permits it, the operation described above can be speeded up by mounting both beads at the same time:

- Follow the steps described under points 1-5 described above but instead of attaching the clip to just the first bead (refer to point 5) clip it to both.
- Lift the rim with the tyre hooked to it and turn it anticlockwise 15-20 cm (clip at 10 o'clock).
- Follow the steps described in points 12-18 above.

MOUNTING WITH THE HOOKED TOOL

- 1) Follow the steps described in points 1-6 for mounting with the disk.
- 2) Move the tool carrier arm to its non-working position. Move it to the inside plane of the tyre and rehook it at this position.
- 3) Check to make sure the hook tool is positioned on the wheel side. If not, press lever (19, Fig. D) and turn it 180°.
- 4) Take the mobile control unit to work position D.
- 5) Move the tool forward until the red reference dot is lined up with the outside edge of the rim and about 5 mm from it (See Fig. O).
- 6) Take the mobile control unit to work position C.
- 7) Move to the outside of the wheel and check the exact position of the tool visually and adjust it as needed. Then turn the spindle clockwise until the clip is at the bottom (6 o'clock). The first bead will be on the rim.
- 8) Remove the clip.
- 9) Take the mobile control unit to work position D.
- 10) Remove the tool from the tyre.
- 11) Move the tool carrier arm to its non-working position. Move it to the outside plane of the tyre and rehook it in this position.
- 12) Turn the tool 180° with lever (19, Fig. D).
- 13) Attach the clip at the bottom (6 o'clock) outside the second bead (See Fig. N).
- 14) Take the mobile control unit to work position C.
- 15) Turn the spindle clockwise to about 90° (clip at 9 o'clock).
- 16) Bring the tool forward until the red reference dot is lined up with the outside edge of the rim and about 5 mm from it. Begin to turn the spindle clockwise and check if, after about 90° of rotation the second bead has started to slip into the centre well. Continue turning until the clip is at the bottom (6 o'clock). The second bead will now be mounted on the rim.
- 17) Follow the steps described in points 13-18 for mounting with the disk since this will ensure that the wheel is removed correctly from the machine.

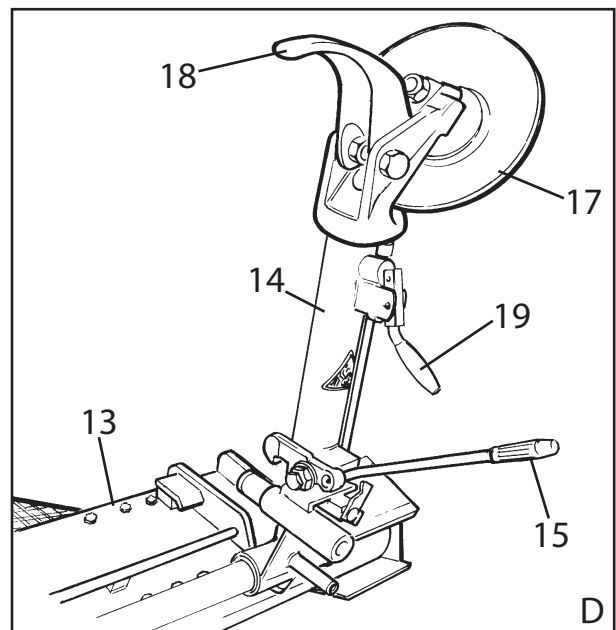
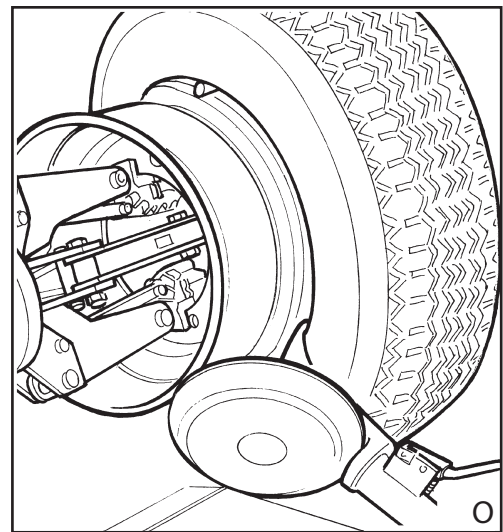
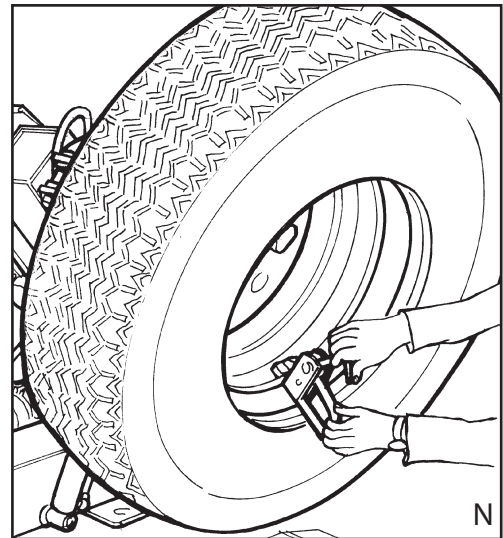

12.3 TUBED WHEELS

BEAD BREAKING

WARNING: Unscrew the bush which fixes the valve when deflating the tyre so that the valve, coming in the inside of the rim, is not an obstacle during bead breaking.

Follow all the steps described previously for bead breaking tubeless tyres.

With tubed tyres, however, stop disk movement as soon as the bead has loosened to avoid damaging the tube inflation valve.

DEMOUNTING

- 1) Take the mobile control unit to work position C.
- 2) Tip the tool carrier arm (14, Fig. D) to its non-working position. Move it to the outside plane of the wheel and rehook it in this position.
- 3) Rotate the wheel and at the same time move the hook tool (18, Fig. D) forward inserting it between rim and bead until it is anchored to the tool.
- 4) Move the rim 4-5 cm from the tool taking care that it does not unhook from the bead.
- 5) Move the hook tool towards the outside until the red reference dot is by the outside edge of the rim.
- 6) Take the mobile control unit to work position B.
- 7) Insert lever LA (see Fig. P) between rim and bead at the right of the tool.
- 8) Press down on the lever and lower the wheel to bring the edge of the rim about 5 mm from the hooked tool.
- 9) Turn the wheel anticlockwise pressing down on lever LA until the bead is completely off.
- 10) Move the tool carrier arm to its non-working position. Lower the spindle until the tyre is pressed down against the platform .
As the platform is moved slightly towards the outside, the tyre will open a little and thus create enough space to remove the inner tube.
- 11) Remove the inner tube and lift the wheel back up.
- 12) Take the mobile control unit to work position D.
- 13) Move the tool carrier arm to the inside plane of the tyre, turn the hook tool 180° and lower the arm to its work position.
Insert it between rim and bead and move it until the bead is by the from edge of the rim (best to do this with the wheel turning).
- 14) Move the rim about 4-5 cm from the tool making sure the hook does not detach from the rim.
- 15) Portarsi con la colonnetta mobile in posizione di lavoro B.
- 16) Move the hook tool so that its red reference dot is about 3 cm inside the rim.
- 17) Insert lever LA between rim and bead at the right of the tool (See Fig. Q).

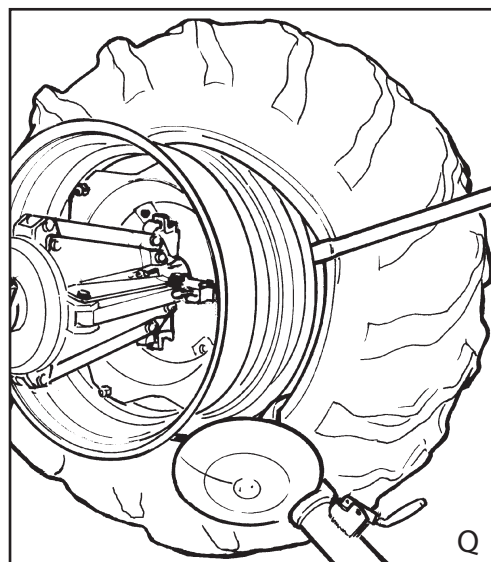

18) Press down on the lever and lower the wheel to bring the edge of the rim about 5 cm from the hooked tool. Turn the wheel anticlockwise pressing down on lever LA until the tyre comes completely off the rim.



DANGER!
When the beads come off the rim, the wheel will fall.
Check to make sure there are no by-standers in the work area.

MOUNTING

1) If the rim has been removed from the spindle, put it back on the spindle as described in the section on "CLAMPING THE WHEEL".

2) Lubricate both beads and the rim with tyre manufacturer recommended lubricant.

3) Attach the PC clip to the outside edge of the rim at the highest point (See Fig. M).



CAUTION!
Make sure the clip is firmly attached to the rim.

4) Take the mobile control unit to work position B.

5) Put the tyre on the platform and lower the spindle (make sure the clip is at the high point) to hook the first bead on the clip.

6) Lift the rim with the tyre hook to it and turn it anticlockwise about 15-20 cm. The tyre will be positioned tilted across the rim.

7) Move the tool carrier arm to its non-working position. Move it to the inside plane of the tyre and rehook it in this position.

8) Check to make sure the hook tool is positioned on the wheel side. If not, press lever (19, Fig. D) and turn it 180°.

9) Take the mobile control unit to work position D.

10) Move the tool forward until the red reference dot is lined up with the outside edge of the rim and about 5 mm from it (See Fig. S).

11) Take the mobile control unit to work position C.

12) Move to the outside of the wheel and check the exact position of the hook visually and adjust it as needed.

Then turn the spindle clockwise until the clip is at the bottom (6 o'clock). The first bead will be on the rim.
Remove the clip.

13) Take the mobile control unit to work position D.

14) Remove the tool from the tyre.

15) Move the tool carrier arm to its non-working position. Move it to the outside plane of the tyre.

16) Turn the tool 180° with lever (19, Fig. D).

17) Take the mobile control unit to work position B.

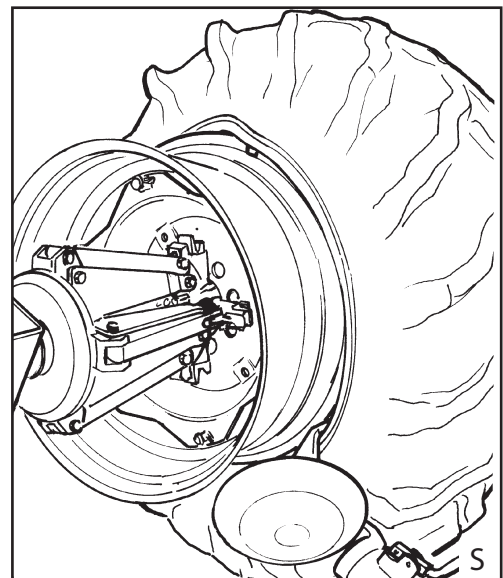
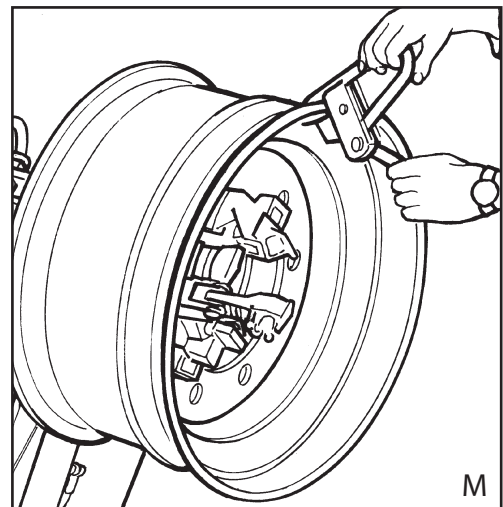

- 18) Turn the spindle until the valve hole is at the bottom (6 o'clock).
- 19) Move the platform (4 Fig. A) under the wheel and lower the spindle until the tyre is pressed down against the platform .
As the platform is moved slightly towards the outside, the tyre will open a little and thus create enough space to insert the inner tube.
NB: The valve hole may be asymmetrical to the centre of the rim. In this case position and insert the inner tube as shown in Fig. T.
Insert the valve through the hole and fix it with its locking ring.
- 20) Place the inner tube in the centre well of the rim.
NB: to facilitate this, turn the spindle clockwise.
- 21) Turn the spindle until the valve is at the bottom (6 o'clock).
- 22) Inflate the inner tube a little (until it has no folds) so as not to pinch it while mounting the second bead.
- 23) Attach an extension to the valve and then remove the locking ring.
NB: The purpose of this operation is to allow the valve to be loose so that it is not ripped out during second bead mounting.
- 24) Take the mobile control unit to work position C.
- 25) Lift the wheel again and attach the PC clip outside the second bead about 20 cm to the right of the valve (See Fig. U).
- 26) Turn the spindle clockwise until the clip is at 9 o'clock.
- 27) Move the tool carrier arm (14, Fig. D) to its working position.
- 28) Bring the tool forward until the red reference dot is lined up with the outside edge of the rim and about 5 mm from it.
- 29) Turn the spindle a little clockwise until you can insert the bead guide lever into its seating on the hook tool (See Fig. V). This lever is furnished as an optional.
- 30) Pull back on this lever which will guide the bead into centre well. Continue to turn the spindle until the tyre is completely mounted on the rim.
- 31) Remove the PC clip. Remove the hook tool by turning the spindle anticlockwise and moving it towards the outside.
- 32) Tip the tool carrier arm to its non-working position.
- 33) Position the platform directly under the wheel and lower the spindle until the wheel rests on the platform.
- 34) Take the mobile control unit to work position B.
- 35) When the wheel is resting on the platform, check to make sure the valve is perfectly centered with its hole. If it is not, turn the spindle slightly to adjust the position. Fix the valve with its locking ring and remove the extension.
- 36) Close the arms of the spindle completely. Support the wheel to prevent it falling off.

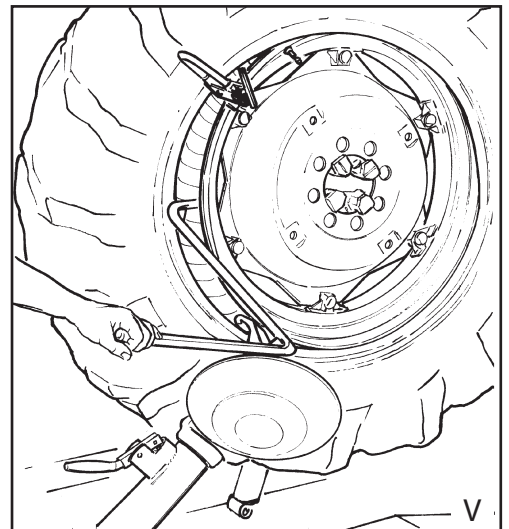
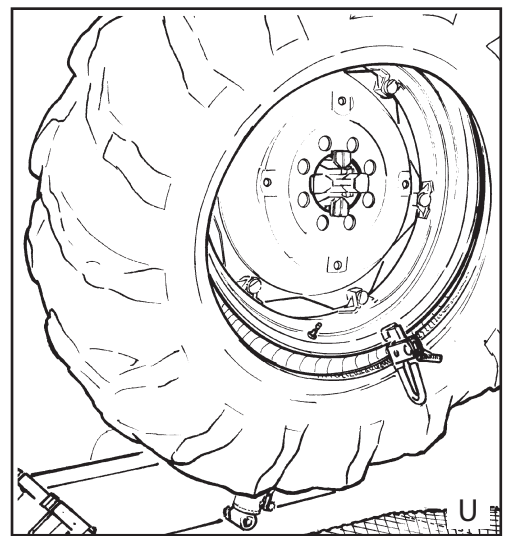
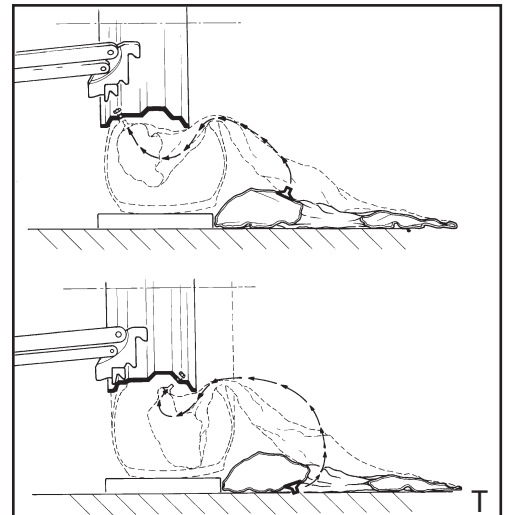

DANGER!
This operation can be extremely dangerous.
Do it manually only if you are certain you can keep the wheel balanced.
For large and heavy tyres an adequate lifting device must be used.

- 37) Move the platform to release the wheel from the spindle.
- 38) Remove the wheel.

12.4 WHEELS WITH SPLIT RING

BEAD BREAKING AND DEMOUNTING

WHEELS WITH 3-PIECE SPLIT RINGS

- 1) Clamp the wheel on the spindle as described previously and check to make sure it has been deflated.
- 2) Take the mobile control unit to work position C.
- 3) Lower the tool carrier arm (14, Fig. D) to its work position until it is locked in position by its hook.
- 4) Position the bead loosener disk level with the rim (See Fig. W).

5) Turn the spindle and at the same time move the disk forward a bit at a time following the contour of the rim until the first bead is completely free.

NB: lubricate while doing this.

CAUTION! If the tyre has an inner tube, work very carefully and be prepared to stop the disk immediately once the bead has been broken so as not to damage the valve and the inner tube.

6) Repeat this procedure but this time bring the disk against the split-ring (See Fig. Z) until the lock ring is freed.

Remove this with the special lever LC (19, Fig. Z) or with the help of the disk.

7) Remove the split-ring.

8) Move the tool carrier arm (14, Fig. D) back from the edge of the rim. Release the hook and tip the arm to its non-working position. Move the tool carrier arm to the inside plane of the wheel.

9) Press lever (19, Fig. D) and turn the tool head 180° which will automatically lock in this position. Lower the arm to its working position.

10) Turn the spindle and at the same time bring the bead loosener disk up against the tyre following the contour of the split-ring until the second bead has been broken.

NB: Lubricate during this process.

Continue to move the disk forward until about half the tyre has demounted from the rim (See Fig. K).

11) Move the tool carrier arm to its non-working position.

12) Move the platform (4, Fig. A) directly under the wheel.

13) Lower the spindle until the wheel is resting on the platform.

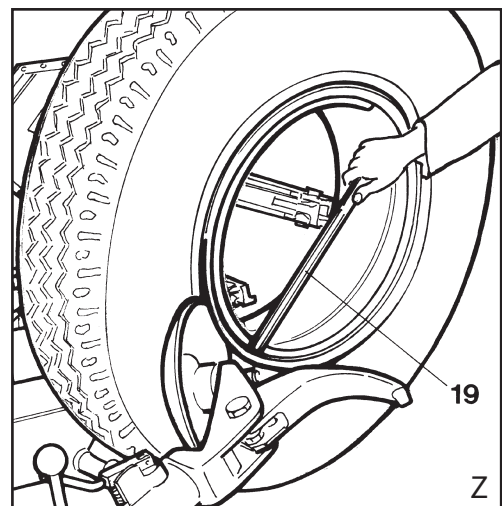
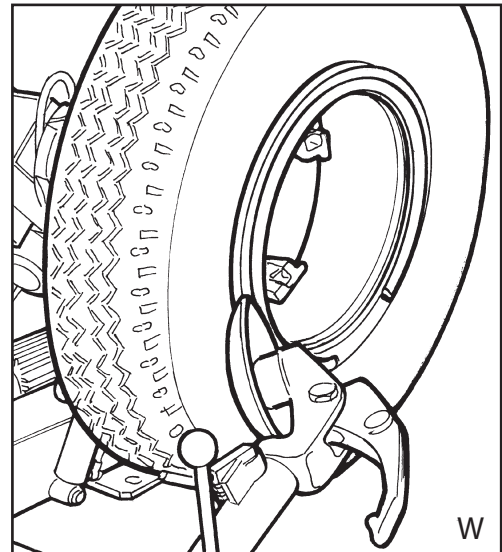

- 14) Take the mobile control unit to work position B.
- 15) Move the platform towards the outside until the tyre is completely off the rim.
Watch out for the valve!

WHEELS WITH 5-PIECE SPLIT RINGS

- 1) Clamp the wheel on the spindle as described previously and make sure it is deflated.
- 2) Take the mobile control unit to work position C.
- 3) Lower the tool carrier arm (14, Fig. D) to its work position until its hook has clicked into position on the bar.
- 4) Use the joystick to position the wheel so that the bead breaker disk touches up against outside edge of the centre well rim.
- 5) Turn the spindle and at the same time move the bead breaker disk forward until the split-ring is detached.
Watch out for the O-ring.
- 6) Repeat this operation but this time move the disk against the split-ring (See Fig. Z) until the locking ring is released.
This ring can be removed with the special LC lever (19, Fig. Z) or with the help of the bead disk.
- 7) Remove the O-ring
- 8) Move the tool carrier arm (14, Fig. D) back from the edge of the rim.
Release the hook and tip the arm to its non-working position.
Move the tool carrier arm to the inside plane of the wheel.
- 9) Press lever (19, Fig. D) and turn the tool head 180° which will automatically lock in this position.
Lower the arm to its working position.
- 10) Take the mobile control unit to work position D.
- 11) Turn the spindle and at the same time bring the bead loosener disk up against the tyre between the rim and bead.
Move the disk into the tyre only when the bead has started to detach from the rim and move the bead to the outside edge of the rim.
NB: Lubricate during this process.

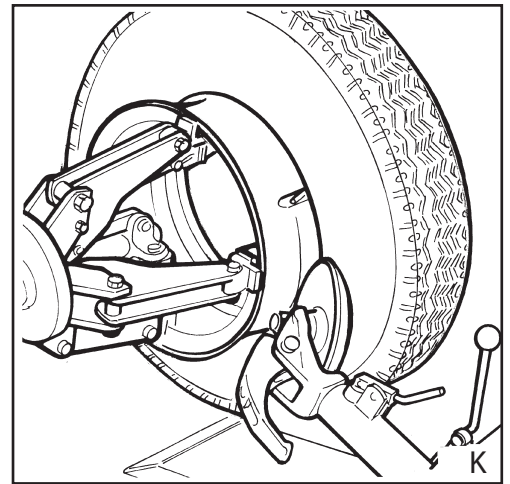

- 12) Tip the tool carrier arm to its non-work position.
- 13) Take the mobile control unit to work position B.
- 14) Move the platform (4, Fig. A) directly under the wheel.
- 15) Lower the spindle until the wheel is resting on the platform.
- 16) Move the platform towards the outside until the tyre together with the split ring comes completely off the rim.
- 17) Remove the rim from the spindle.
- 18) Position the tyre on the platform with the splint ring turned towards the spindle.
- 19) Clamp the split ring on the spindle as explained in the section of CLAMPING THE WHEEL.

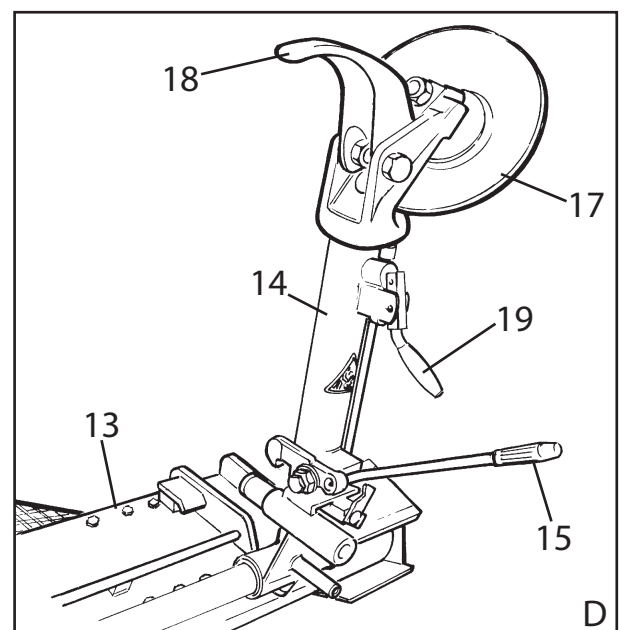



DANGER!
The tyre is not attached to the split ring completely safely.
Any strain on it during positioning or clamping operations could cause it to detach and fall.

20) Take the mobile control unit to work position D.

21) Lift the wheel.

22) Move the tool carrier arm back to its work position.

23) Position the spindle so that the bead breaker disk is lined up with the bead.

24) Turn the spindle and move the disk forward until the tyre comes completely off the split ring.
NB: This double bead breaking procedure can be eliminated by using the PAIR OF BC CLAMPS (optional) that fix the split-ring to the rim so that they are broken out at the same time.
The BC clamps come complete with operating instructions.

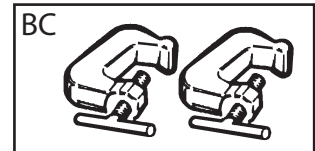

DANGER!
When the beads come off the rim, the wheel will fall.
Check to make sure there are no by-standers in the work area.

MOUNTING

WHEELS WITH 3-PIECE SPLIT RINGS

1) Move the tool carrier arm to its non-working position.
If the rim has been removed from the spindle, put it back on the spindle as described in the section on "CLAMPING THE WHEEL".
N.B.: If the tyre is tubed, position the rim with the valve slot at the bottom (6 o'clock).

2) Lubricate both beads and the rim with tyre manufacturer recommended lubricant.

3) Take the mobile control unit to work position B.

4) Move the platform to be able to place the tyre on it.
NB: If the tyre is tubed, position the rim with the valve slot at the bottom (6 o'clock).

5) Lower or raise the spindle to centre the rim and the tyre.

6) Move the platform forward until the rim is inserted into the tyre.
CAUTION! If the tyre is tubed push the valve inside so as not to damage it.
Move forward with the platform until rim is completely in the tyre.

7) Bring the tool carrier arm to the outside plane and lower it to its work position with the disk towards the wheel.
NB: If the tyre is not inserted sufficiently on the rim, move the spindle until the tyre bead is by the disk.
Bring the disk forward (with the spindle turning) until it is completely inserted.

8) Put the split-ring on the rim and then install the locking ring with the help of the disk as shown in Fig. Y.

9) Move the tool carrier arm to its non-working position and, at the same time, close the spindle arms.
Support the wheel so that it does not fall off.

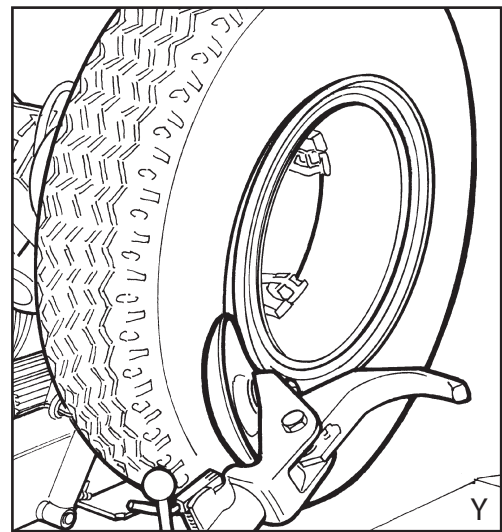



DANGER!
This operation can be extremely dangerous.
Do it manually only if you are certain you can keep the wheel balanced.
For large and heavy tyres an adequate lifting device must be used.

- 10) Move the platform to free the wheel from the spindle.
- 11) Remove the wheel.

WHEELS WITH 5-PIECE SPLIT RINGS

- 1) Move the tool carrier arm to its non-working position. If the rim has been removed from the spindle, put it back on the spindle as described in the section on "CLAMPING THE WHEEL".
- 2) Lubricate both beads and the rim with tyre manufacturer recommended lubricant.
- 3) Take the mobile control unit to work position B.
- 4) Move the platform to be able to place the tyre on it.
- 5) Lower or raise the spindle to centre the rim and the tyre.
- 6) Move the platform forward until the rim is inserted into the tyre.
Move forward with the platform until rim is completely in the tyre.
- 7) Put the split-ring on the rim and (with the lock ring already mounted).
NB: If the rim and the split-ring have slits for fixing devices, make sure they are lined up with each other.
- 8) Take the mobile control unit to work position C.
- 9) Move the tool carrier arm to the outside in its work position with the bead breaker disk turned towards the wheel.
NB: If the split-ring is not inserted sufficiently on the rim, move the spindle until the split-ring is by the disk.
Bring the disk forward (with the spindle turning) until you "discover" the O-ring seating.
- 10) Lubricate the O-ring and its seating.
- 11) Take the mobile control unit to work position B.
- 12) Position the locking ring on the rim with the help of the disk as shown in Fig. Y.
- 13) Move the tool carrier arm to its non-working position and close the spindle arms completely.
Support the wheel so that it does not fall off the spindle.



DANGER!
This operation can be extremely dangerous.
Do it manually only if you are certain you can keep the wheel balanced.
For large and heavy tyres an adequate lifting device must be used.

- 14) Move the platform to free the wheel from the spindle.
- 15) Remove the wheel.



DANGER!!
Do not inflate the tyre with the wheel mounted on the spindle.
Tyre inflation is dangerous and should only be done by removing the wheel from the spindle and placing it inside a safety cage.

13. OPTIONAL ACCESSORIES

ATTENTION: All TECO accessories are always supplied complete with installation and operating instructions.

The following optional accessories are available for the TECO 55A tyre changer:

PAR Pliers for alloy rims

Used instead of PC, they make it possible to work with alloy rims, without damaging them.

BGL Bead guide lever

It facilitates bead mounting of tubed wheels.

BC Pair of bead clamp

Used on wheels with split ring, they allow bead breaking of both rim and split ring.

JAR Set of 4 jaws for alloy rims

Mounted on the jaws of the chuck, they allow to operate on alloy rims without damaging them.

SE Set of extensions for self-centering chuck

Mounted on the turntable jaws, they allow to lock rims from 48" to 56" without central flange.

TR1 Tubeless roller

Mounted on the tool holding arm, it facilitates bead breaking of tubeless wheels.

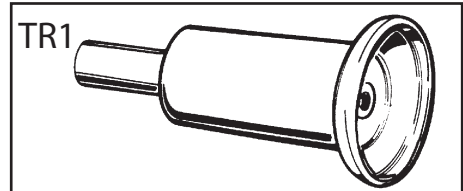
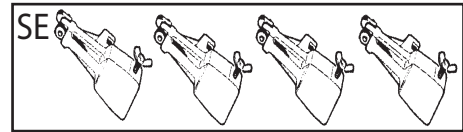
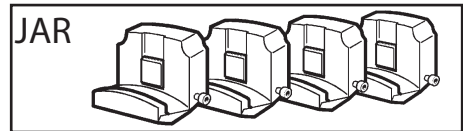
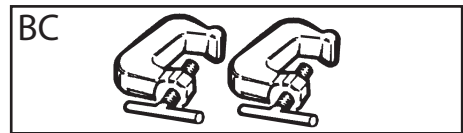
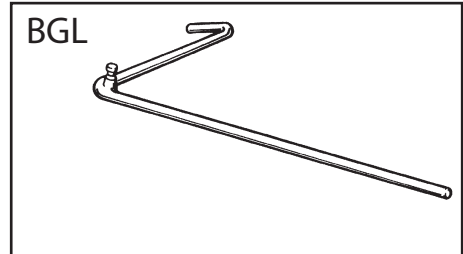
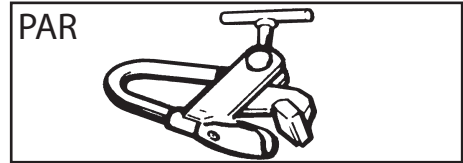

14. MOVING THE MACHINE

The TECO 55A tyre changer has got a fork (1, Fig. A) which has been positioned there on purpose for moving the machine.

Follow these instructions:

- 1) Low the turntable holding arm (2, Fig. A) completely down.
- 2) Close completely the jaws of the chuck (3, Fig. A).
- 3) Bring the sliding table (4, Fig. A) at the end of its travel, near the arm.
- 4) Insert into the lifting fork a hoisting belt (at least 60 mm wide and of a length sufficient to bring the hook of the belt above the tyre changer).
- 5) With the special belt ring bring the 2 ends of the belt together and lift with a sufficiently strong lifting truck.

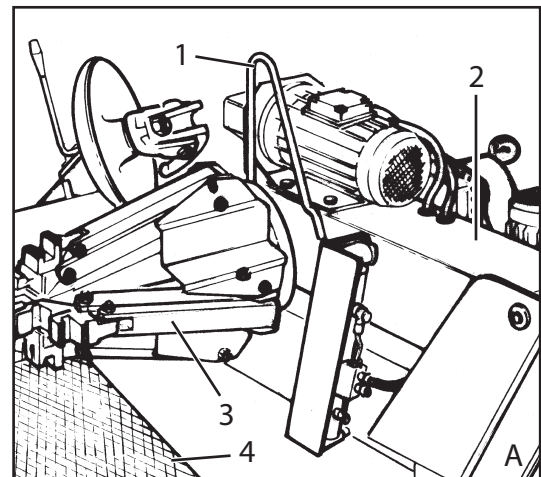

15. STORING

If the machine is to be stored for a long time (3-4 months) you have to:

- 1) Close the jaws of the chuck; low the chuckholding arm down; low the tool holding arm down, in working position.
- 2) Disconnect the machine from all power sources.
- 3) Grease all the parts that could be damaged if they dry out:
 - the chuck
 - the slot of the tool holding arm
 - the slides of the carriage
 - the tool
- 4) Empty oil/hydraulic fluid reservoirs and wrap the machine in a sheet of protective plastic to prevent dust from reaching the internal working parts.

If the machine is to be working again after a long storing period, it is necessary to:

- 1) put the oil into the reservoirs again.
- 2) restore the electric connection.

16. SCRAPPING A MACHINE

When your machine's working life is over and it can no longer be used, it must be made inoperative by disconnecting it from all power sources. This equipment is considered as special waste material, and should therefore be broken down into uniform parts and disposed of in compliance with current laws and regulations.

If the packing is polluting or non-biodegradable, deliver them to appropriate handling stations.

ENVIRONMENTAL INFORMATION

This product may contain substances that can be hazardous to the environment or to human health if it is not disposed of properly. We therefore provide you with the following information to prevent releases of these substances and to improve the use of natural resources.

Electrical and electronic equipments should never be disposed of in the usual municipal waste but must be separately collected for their proper treatment.



The crossed-out bin symbol, placed on the product and in this page, remind you of the need to dispose of properly the product at the end of its life.

In this way it is possible to prevent that a not specific treatment of the substances contained in these products, or their improper use, or improper use of their parts may be hazardous to the environment or to human health. Furthermore this helps to recover, recycle and reuse many of the materials used in these products.

For this purpose the electrical and electronic equipment producers and distributors set up proper collection and treatment systems for these products.

At the end of life your product contact your distributor to have information on the collection arrangements.

When buying this new product your distributor will also inform you of the possibility to return free of charge another end of life equipment as long as it is of equivalent type and has fulfilled the same functions as the supplied equipment.

A disposal of the product different from what described above will be liable to the penalties prescribed by the national provisions in the country where the product is disposed of.

We also recommend you to adopt more measures for environment protection: recycling of the internal and external packaging of the product and disposing properly used batteries (if contained in the product).

With your help it is possible to reduce the amount of natural resources used to produce electrical and electronic equipments, to minimize the use of landfills for the disposal of the products and to improve the quality of life by preventing that potentially hazardous substances are released in the environment.

17. FIRE-FIGHTING



WARNING!
If this machine catches fire, use powder or CO² extinguishers only.

18. DATA ON SERIAL PLATE

The manufacturer's Serial plate is fixed on the back of the machine.

It gives the following information:

- 1- Manufacturer name and address;
- 2- Model;
- 3- Serial number;
- 4- Phases;
- 5- Voltage requirements;
- 6- Frequency;
- 7- Rated draw;
- 8- Power absorbed;
- 9- Max. hydraulic pressure
- 10- Weight;
- 11- Year.

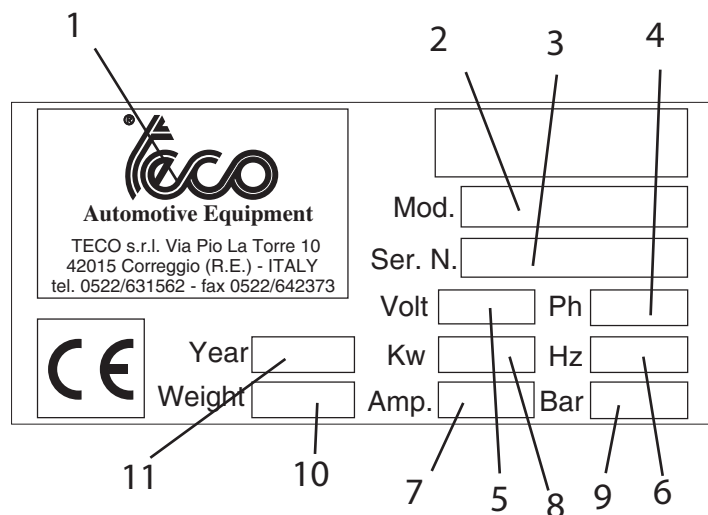

19. ROUTINE MAINTENANCE



WARNING!
All maintenance work must be done only after the plug has been disconnected from the power supply.

To ensure that this TECO 55A tyre changer works perfectly over the years, carry out the routine maintenance schedule described below:

- 1) Lubricate the following parts from time to time, after a thorough cleaning with naphtha:
 - the various swivels on the spindle
 - the tool bracket slide runner
 - the carriage guide plate.

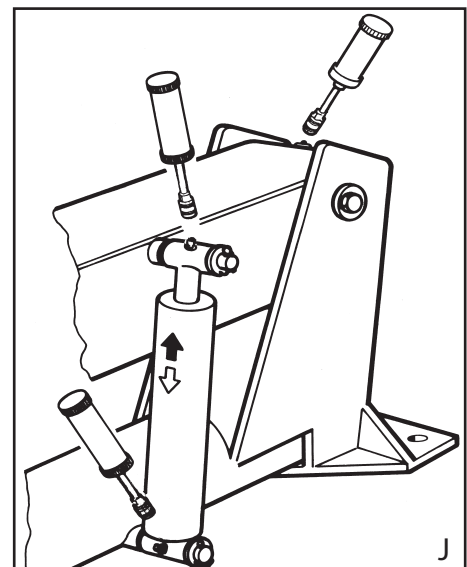

2) Grease the spindle bracket lift cylinder from time to time and also its swivel.
Add the grease through the grease nipples (See Fig. J) using ordinary lubricating grease.

3) Periodically check the oil level in the hydraulic power unit using the dipstick (30, Fig. J/1).

If the level is below the minimum notch, top up with ESSO NUTO H 46 oil or equivalents (e.g. AGIP OSO 46, SHELL TELLUS OIL 46, MOBIL DTE 25, CASTROL HYPIN AWS 46, CHEVRON RPM EP HYDRAULIC OIL 46, or BP ENERGOL HLP).

Unscrew the cap (30, Fig. J/1), add the oil and screw the cap back on.

4) From time to time check the oil level in the gear unit which, when the tool carrier bracket is completely lowered at end travel, should not show the sight glass on the gear casing as completely empty.

If necessary top up with Esso Spartan EP 320 or similar oil (eg, Agip F1 REP 237, BP GRX P 320, Chevron Gear Compound 320, Mobil Gear 632, Shell Omala Oil 320, Castrol Alpha SP 320).

Unscrew the cap (31, Fig. J/2), put oil in and screw the cap again.

NB: If the oil in the gear unit or the hydraulic power pack has to be changed, note that the gear unit casing and the power pack reservoir have specific drain plugs.



WARNING!
Dispose of the used oil following current regulations.

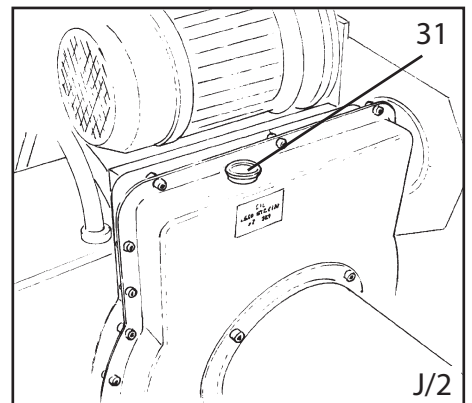
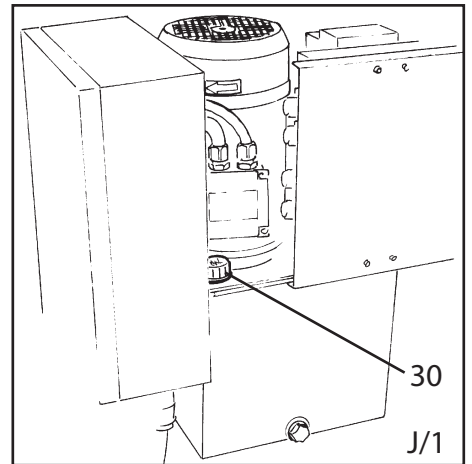

20. TROUBLE SHOOTING

PROBLEM

After having switched the general button on the electric pack, the general warning light does not light on and no control can function.

CAUSES

- 1) The power plug is not inserted.
- 2) No power from the mains electric supply.

REMEDIES

- 1) Insert the plug correctly in its socket.
- 2) Reset the mains electric supply.

PROBLEM

After having switched the general button on the general warning light also switches on but the motor on the hydraulic power pack does not function.

CAUSES

- 1) The magneto-thermic switch for motor protection is working.

REMEDIES

- 1) Call for technical aid to see what is the problem and restore the machine.

PROBLEM

The manometer (21, Fig. A) reads a pressure value below 130 bar \pm 5%.

CAUSES

1) The oil in the power pack is below minimum level.

REMEDIES

1) Read the paragraph "MAINTENANCE" to add oil.

PROBLEM

There is a slowing down at an the tyre changer's movements.

CAUSES

1) The oil in the power pack is below minimum level.

REMEDIES

1) Read the paragraph "MAINTENANCE" to add oil.

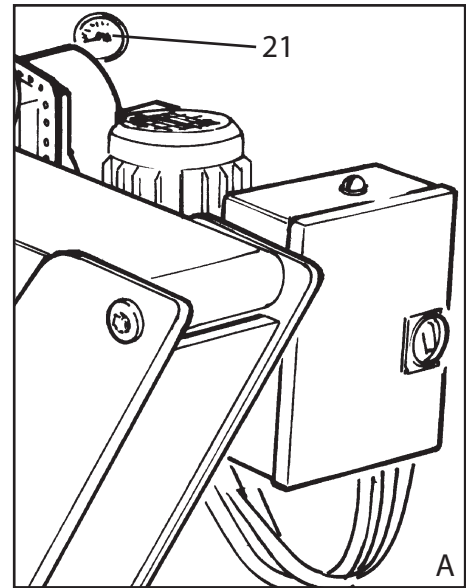

WARNING: If, in spite of the above mentioned indications the tyre changer does not work properly, do not use it and contact your nearest TECO technical assistance centre.

I

La TECO si riserva di apportare modifiche alle proprie macchine in qualsiasi momento e senza preavviso.

Non si risponde per danni e/o lesioni derivanti da un utilizzo diverso da quello qui specificato o dalla inosservanza delle istruzioni contenute nel presente manuale.

PUBBLICAZIONI TECO - Edizione 03/2008 - STAMPATO IN ITALIA

GB

TECO reserves the right to modify its machine at any time without prior notice.

TECO declines any and all liability for injury to persons or damage to things caused by use of the machine other than that specified or failure to observe the instructions detailed in this manual.

TECO PUBLISHING - Edition 03/2008 - PRINTED IN ITALY

F

TECO se réserve le droit d'apporter les modifications à ses machines à tout moment et sans préavis.

TECO décline toute responsabilité en cas de dommages dus à une mauvaise utilisation ou à l'inobservation des instructions de cette notice.

PUBLICATIONS TECO - Edition 03/2008 - IMPRIMÉ EN ITALIE

D

Firma TECO behält sich das Recht vor, jederzeit ohne Vorbescheid Änderungen an ihren Maschinen vorzunehmen.

Der Hersteller haftet nicht für Schäden und/oder Verletzungen infolge der Benutzung, die nicht der hier beschriebenen entspricht, oder infolge der Nichtbeachtung der Anweisungen, die in diesem Handbuch stehen.

TECO-VERÖFFENTLICHUNGEN - Ausgabe 03/2008 - IN ITALIEN GEDRUCKT

E

La TECO se reserva el derecho de realizar modificaciones en sus máquinas en cualquier momento sin previo aviso.

No se hace responsable de los daños y/o lesiones provocados por un uso diferente al que se especifica aquí o por no respetar las instrucciones de este manual.

PUBLICACIONES TECO - Edición 03/2008 - ESTAMPADO EN ITALIA



Automotive Equipment

TECO s.r.l. via Pio La Torre n.10 - 42015 Correggio (RE)

ITALY tel. 0522/631562 - fax 0522/642373

Home Page : www.teco.it - E-mail : teco@teco.it