

C310



DIGITAL BALANCING
MACHINE WITH
AUTOMATIC SPIN
AND INTEGRATED LIFT
FOR TRUCK
WHEELS



CEMB
GARAGE EQUIPMENT

C310

CORE OF TECHNOLOGY

New automatic-spin balancing machine suitable for operating on truck, bus and car wheels up to 200 kg in weight. The innovative solution of the spindle shaft that lowers, guarantees a safer and easier centring even with large wheels. Essential and easy to use, it offers a wide range of programs capable of satisfying every need while guaranteeing excellent performance. Two operating pushbuttons make the measurement spin safe for the operator.

- **VDD Virtual Direct Drive** - very quick and maintenance free measurement system **CEMB PATENT**
- **Automatic wheel spin and braking**
- Software programs for the professionals: **SPLIT, OPT, ALU**
- **Extended gauge** for diameter and distance measurement of rims up to 32" and manual setting of the wheel width in the case of clip-on counterweights
- **ALU-S balancing mode** (adhesive weights on the internal rim planes) with specific counterweight position indicator
- **Spacious and sturdy** rotational **weight-tray** with differentiated compartments for housing cones, clip weights, alu, grippers
- **Mobile spindle shaft** for perfect centring of the wheel





Press&Start

NO WHEEL GUARD? NO PROBLEM!

Two pushbuttons, positioned on the side of the machine, allow the measurement spin to be carried out in full safety for the operator, ensuring ease of use and saving time.

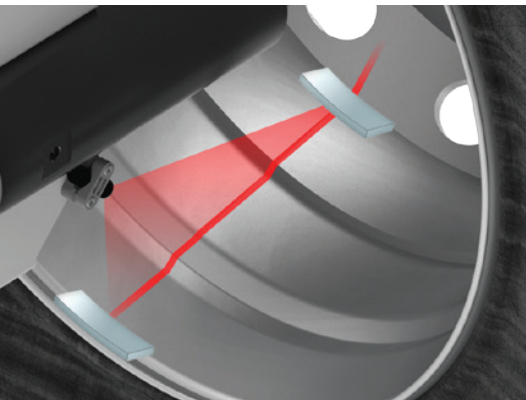

Laser Line

SOPHISTICATED RED LINE LASER INDICATOR

Laser line to facilitate the correct positioning of the adhesive counterweights in the 6 o'clock position, increasing the balancing accuracy.

LIFTING SPINDLE - INNOVATIVE WHEEL LIFT



PERFECT CENTRING, ACCURATE BALANCING!

The spindle shaft rises and lowers to facilitate wheel loading, ensuring perfect centring, ideal condition for better balancing accuracy. Loading on the ground, mount the wheel on the spindle, lift.

SAFE WHEEL CLAMPING THANKS TO THE MOBILE SPINDLE

No risk for the operator since the wheel, when raises, is already clamped on the spindle, in complete safety.

EASIER AND FASTER WHEEL HANDLING

The sliding trolley, with a height of only 59 mm, the lowest available on the market, allows a faster and easier loading of the wheel, with reduced effort for the operator.

NOTE: sliding trolley available as an option.

CEMB INNOVATION

STANDARD ACCESSORIES



In 1952 Cemb created the cone adapters for balancing machines and since then the company continued developing and producing high precision centering systems for any type of wheel. Cemb does not recommend the use of non-original adapters on its balancing machines.

Standard equipment composed of quick nut with spacer ring, pincer-hammer, 300g. counterweight and WDC gauge.



AVAILABLE ACCESSORIES - Especially designed for car manufacturers



IV/V CONES-GG-G40 KIT 41FF054929

To centre truck or bus wheels with a central hole of 202/221/281 mm Ø. Made up of IV and V cones, G40 disc and GG ring

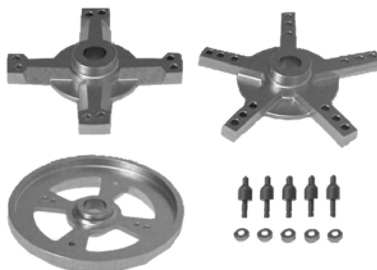

SR215 41FF67879

To centre wheels with 8 holes on 275/285.75 mm Ø and with 10 holes on 225/285.75/335 mm Ø. Supplied with centring adaptor, 5 and 4 armed spiders, stud bolts and screws



CAR ADAPTOR KIT 41FF054930

For wheels with a central hole of 45-194 mm Ø. Consists of 4 cones and G40 disc.

FOR MORE INFORMATION SEE THE COMPLETE BROCHURE ON THE WEB SITE. www.cemb.com

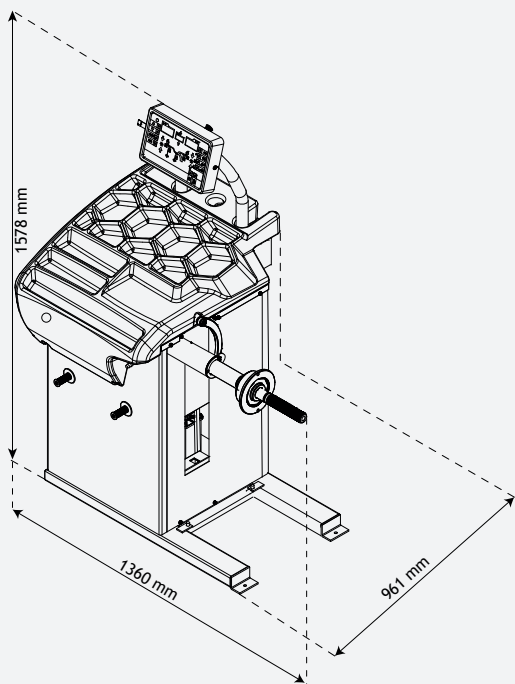

Single phase power supply	230 V/1ph/50 Hz 115V/1ph/60 Hz
Max. absorbed power	1,1 kW
Balancing speed	130 rpm (for car) / 80 rpm (for truck)
Measuring cycle for car/truck wheel	8 ÷ 20 s
Measurement uncertainty	± 0.5 g
Resolution	1 g for car / 10 g for truck
Average noise	< 70 dB (A)
Rim width setting range	1.5" ÷ 20" / 40 ÷ 510 mm
Rim diameter setting range	10" ÷ 30" / 265 ÷ 765 mm
Min./Max. compressed air pressure	8 ÷ 12 kg/cm ² / ~ 0.8 ÷ 1.2 MPa ~ 8 ÷ 12 bar / ~ 120 ÷ 165 psi
Max. wheel weight	200 kg
Max. wheel diameter	1380 mm
Machine weight	190 kg



CEMB

BALANCING MACHINES

CEMB S.p.A.

Via Risorgimento, 9
23826 Mandello del Lario (LC) - Italy
www.cemb.com



Garage equipment division
CEMB - ITALY
Plant and Training Center
Phone +39 0341 706111
garage@cemb.com

CEMB USA - BL Systems Inc.
2873 Ramsey Road
Gainesville, GA 30501 - USA
Phone +001 678 717 1050
Fax +001 678 717 1056
sales@cemb-usa.com



All the data and features mentioned in this catalogue are purely for information and do not constitute any commitment on the part of our company, which reserves the right to make any and all alterations it may consider suitable without notice.