

ER 15

ErGoFast line

SPACE-SAVING
3D BALANCER
WITH VIDEO
TOUCHSCREEN



CEMB



ER15

FROM CEMB EXPERIENCE

- **ER15** balancer is the result of CEMB consolidated experience in the manufacturing of high technology garage and industrial balancers since 1946. Development and cooperation with the most important car and tyre manufacturers guarantee to the professionals in the garage equipment field:
- **Reliability**
- **Easy and quick use**
- **Accuracy**
- **3D measures**
- **Reduced cycle time!**

INNOVATIVE DESIGN:

ERGOFAST

- With **ER15**, CEMB widens its range of products **ERGOFAST**, maintaining the concepts of ergonomics and practicality together with the original design
- **WBA Wheel Best Access**
Wide space to work inside the rim
- New 12" Video Touchscreen
- Ergonomic tool positioning
CLOSE AT HAND!

CORE OF TECHNOLOGY

- **Automatic gauge** to measure the distance and diameter of rims of up to 28" with an innovative clip to hold the adhesive weight
- **Virtual Sonar** for 3D measurements of wheels that, in cases of metal rims and absence of sonar, calculates the width of the rim
- **AutoAdaptive Mode** - The new tolerance calculation system
- **12" Video Touchscreen** - intuitive, durable and easy to use
- **Electromagnetic brake** for the lock of the wheel in the exact weight position
- Software programs for the professionals: **SPLIT, OPT, ALU**
- **ALU-S 3D Balancing mode** - Adhesive weights on the internal rim planes with specific counterweight position indicator
- **Automatic approach** of the wheel within 15° from the point of application of the balancing weight, to allow the operator to position it correctly, with minimum movement
- **Low balancing speed**
- Latest generation **VDD Virtual Direct Drive** - Super-fast and extremely accurate measuring system





Virtual Sonar

INNOVATIVE 3D SOFTWARE THAT CALCULATES RIM WIDTH

- After acquiring the position of the first plane of correction, the new software **Virtual Sonar** calculates the width of the rim, identifying a possible range of external correction planes.
- During the measurement spin, **Virtual Sonar** verifies that it is possible to fall within the tolerance with the correction indicated on all possible external planes.
- If there is even one possible plane for which the required correction does not allow the residual unbalance to fall within the tolerance range (calculated with AutoAdaptive software), the machine will request manual entry of the rim width in mm.

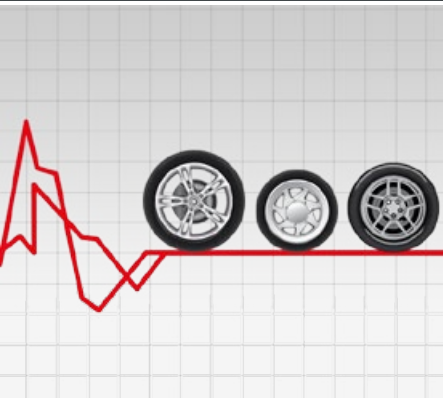

AutoAdaptive Mode

THE NEW TOLERANCE CALCULATION SYSTEM

- The innovative tolerance calculation system **AutoAdaptive Mode** is based on the evaluation of the residual imbalance limit value corresponding to an acceptable perceived vibration. For each wheel that is balanced, the software **AutoAdaptive Mode** detects weight and dimensions and calculates the tolerance value that will cancel any vibration perceived on the steering wheel. **AutoAdaptive Mode** grants the highest comfort when driving and saves balancing time.

In 1952 Cemb created the cone adapters for balancing machines and since then the company continued developing and producing high precision centering systems for any type of wheel. **Cemb does not recommend the use of non-original adapters on its balancing machines.**

STANDARD ACCESSORIES



Standard equipment UC20/2 GL40 composed of: quick locknut GL40 and 3 cones kit



MANUAL LOCKING

41FF83146

Locknut Kit (quick locknut GL40, with sleeve and ring



41FF034416

3 cones kit Ø 45÷110 mm, pincer-hammer and 60 g. counterweight



OPTIONAL ACCESSORIES - Especially designed for car manufacturers



RL CUP 41FF79255

Large plastic cup with polyurethane protection ring for light alloy rims.

VL/2 CONE + G36 DISC 41FF86174

Kit for light truck wheels (Ø 97÷170mm central hole).

MT CONE 40FF57321

High precision graduated cone for German cars (with central hole Ø 56,5 / 57 / 66,5 / 72,5 mm).

UH20/2 41FF42048

Universal adapter for all wheels with 3,4,5,6 holes (pitch circle Ø 95-210 mm) complete with high precision back centering double cone (Cemb patent) for wheels with/without central hole (Renault, Peugeot and Citroën). Grants double accuracy compared to similar adapters on the market.

SR4 - SR5 - SR5/2 - SRUSA

Stud adapters for rim protection and high precision centering for wheels with 4 or 5 holes. Studs are made of two pieces, elastically coupled: pressure is therefore homogeneous on all the holes.

MERCEDES KIT 41FF88003

High precision kit composed of: 3 cones (Ø 57 - Ø 66,5 - Ø 84/85mm) + 1 pressure spring, according to Mercedes Benz specifications.

PEUGEOT-CITROËN KIT 41FF73171

High precision kit composed of: 1 bush Ø 60mm + 2 cones (Ø 62 ÷ 68 mm and Ø 54 ÷ 60 mm). Developed according to Peugeot and Citroën specifications.

RENAULT KIT 41FF77152

High precision kit composed of: 5 bushes (Ø 60 / 66 / 71 / 88 / 129,9 mm). Developed according to Renault specifications.

FOR MORE INFORMATION SEE THE COMPLETE BROCHURE ON THE WEB SITE:

www.cemb.com

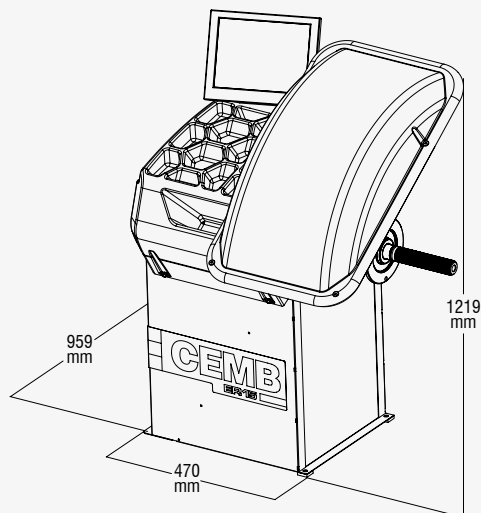

Single phase power supply	115 / 230 V 50/60 Hz
Max. absorbed power	0,15 kW
Balancing speed	100 rpm
Measuring cycle for 15 kg (33 lb) wheel	4.7 s
Measurement uncertainty	0,5 g
Average noise	< 70 dB (A)
Rim width setting range	1.5" ÷ 20" / 40 ÷ 510 mm
Rim diameter setting range	10" ÷ 30" / 265 ÷ 765 mm
Max. wheel weight	< 75 kg
Machine weight	110 kg



Zero Weight Lift

OPTION TO REDUCE ANY EFFORT

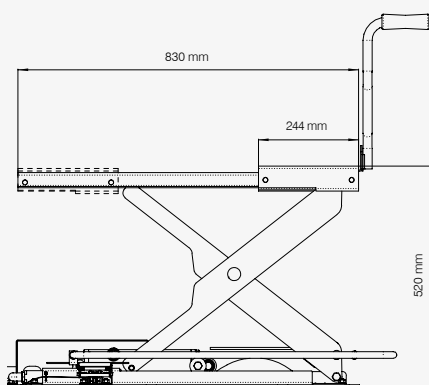

Wheel loading and removal without effort or adjustment

- **PERFECT CENTERING**
Wheel automatic lifting
Ideal centering and more accurate balancing
- **QUICK**
Quicker than any other traditional lift
A single pedal controls the whole working cycle
- **AUTOMATIC**
Electronic system with PLC
- **UNIVERSAL**
Applicable to any CEMB balancing machine

For more information see the complete brochure on the web site www.cemb.com



CEMB

BALANCING MACHINES

CEMB S.p.A.
Via Risorgimento, 9
23826 Mandello del Lario (LC) - Italy
www.cemb.com



Garage equipment division
CEMB - ITALY
Plant and Training Center
Phone +39 0341 706111
garage@cemb.com



All the data and features mentioned in this catalogue are purely for information and do not constitute any commitment on the part of our company, which reserves the right to make any and all alterations it may consider suitable without notice.