

ER 63



WHEEL
BALANCING
MACHINE
WITH DIGITAL
MULTIFUNCTION
DISPLAY



ER 63



ER 63SE



CEMB



ER63

FROM CEMB EXPERIENCE

- **ER63** balancer is the result of CEMB consolidated experience in the manufacturing of high technology garage and industrial balancers since 1946. Development and cooperation with the most important car and tyre manufacturers guarantee to the professionals in the garage equipment field:
- **Reliability**
- **Easy and quick use**
- **Accuracy**
- **Completely configurable**
- **Reduced cycle time!**

INNOVATIVE DESIGN:

ERGOFAST

- With **ER63**, CEMB widens its range of products **ERGOFAST**, maintaining the concepts of ergonomics and practicality together with the original design
- **WBA Wheel Best Access**
Wide space to work inside the rim
- Digital multifunction display
- Ergonomic tool positioning **CLOSE AT HAND!**

PNEUMATIC LOCKING



CORE OF TECHNOLOGY

- **VDD Virtual Direct Drive** - very quick and maintenance free measurement system **CEMB PATENT**
- Lock of wheel in the correction position by means of an **electromagnetic brake**
- Software programs for the professionals: **SPLIT, OPT, ALU**
- **Extended gauge** for diameter and distance measurement of rims up to 28" with new pincer to hold the adhesive weight
- **ALU-S balancing mode** (adhesive weights on the internal rim planes) with specific counterweight position indicator (position repeater)
- **LASER** for weight positioning inside the rim
- **Automatic approach** of the wheel within 15° from the point of application of the balancing weight, to allow the operator to position it correctly, with minimum movement
- **ER63SE - Pneumatic wheel locking CEMB PATENT**
Floor to floor time reduction / Extremely easy and quick to use / Very accurate wheel centering





Sonar LA

- LA SONAR for automatic measurement of the wheel width

STANDARD ACCESSORIES

In 1952 Cemb created the cone adapters for balancing machines and since then the company continued developing and producing high precision centering systems for any type of wheel.

Cemb does not recommend the use of non-original adapters on its balancing machines.

Standard equipment UC20/SE2 composed of: SE kit, 3 cones Kit and WDC gauge



PNEUMATIC LOCKING

41FF034417
SE Kit (ring, quick locking sleeve SE2, SE spacer)



41FF034416
3 cones kit \varnothing 45÷110 mm, pincer-hammer and 60 g. counterweight



46FC77653
Width gauge



Standard equipment UC20/2 GL40 composed of: quick locknut GL40, 3 cones Kit and WDC gauge



MANUAL LOCKING

41FF83146
Locknut Kit (quick locknut GL40, with sleeve and ring)



41FF034416
3 cones kit \varnothing 45÷110 mm, pincer-hammer and 60 g. counterweight



46FC77653
Width gauge



OPTIONAL ACCESSORIES - Especially designed for car manufacturers



RL CUP 41FF79255

Large plastic cup with polyurethane protection ring for light alloy rims.

VL/2 CONE + G36 DISC 41FF86174

Kit for light truck wheels (\varnothing 97÷170mm central hole).

MT CONE 40FF57321

High precision graduated cone for German cars (with central hole \varnothing 56,5 / 57 / 66,5 / 72,5 mm).

UH20/2 41FF42048

Universal adapter for all wheels with 3,4,5,6 holes (pitch circle \varnothing 95-210 mm) complete with high precision back centering double cone (Cemb patent) for wheels with/without central hole (Renault, Peugeot and Citroën). Grants double accuracy compared to similar adapters on the market.

SR4 - SR4/SE - SR5 - SR5/SE SR5/2 SR5/2/SE - SRUSA - SR/USA/SE

Stud adapters for rim protection and high precision centering for wheels with 4 or 5 holes. Studs are made of two pieces, elastically coupled: pressure is therefore homogeneous on all the holes.

MERCEDES KIT 41FF88003

High precision kit composed of: 3 cones (\varnothing 57 - \varnothing 66,5 - \varnothing 84/85mm) + 1 pressure spring, according to Mercedes Benz specifications.

PEUGEOT-CITROËN KIT 41FF73171

High precision kit composed of: 1 bush \varnothing 60mm + 2 cones (\varnothing 62 ÷ 68 mm and \varnothing 54 ÷ 60 mm). Developed according to Peugeot and Citroën specifications.

RENAULT KIT 41FF77152

High precision kit composed of: 5 bushes (\varnothing 60 / 66 / 71 / 88 / 129,9 mm). Developed according to Renault specifications.

FOR MORE INFORMATION SEE THE COMPLETE BROCHURE ON THE WEB SITE

www.cemb.com



AVAILABLE IN TWO VERSIONS:

ER63 Manual locking and LA sonar

ER63SE Pneumatic locking and LA sonar

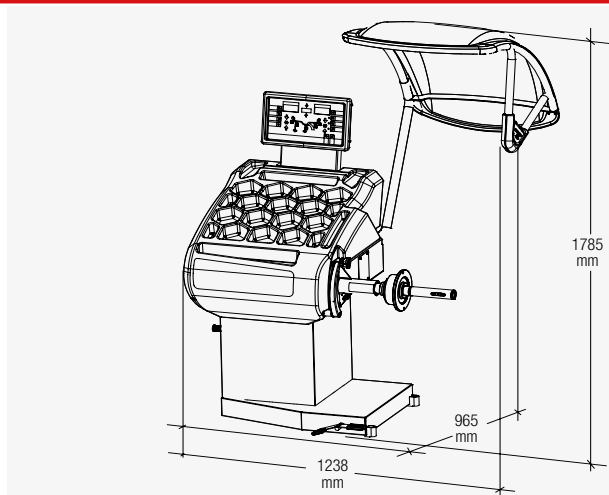

Single phase power supply	115 / 230 V 50/60 Hz
Max. absorbed power	0,15 kW
Balancing speed	100 rpm
Measuring cycle for 15 kg (33 lb) wheel	4.7 s
Measurement uncertainty	0,5 g
Average noise	< 70 dB (A)
Rim width setting range	1.5" ÷ 20" / 40 ÷ 510 mm
Rim diameter setting range	10" ÷ 30" / 265 ÷ 765 mm
Min./Max. compressed air pressure	7 ÷ 10 kg/cm ²
	~ 0.7 ÷ 1 MPa
	~ 7 ÷ 10 bar
	~ 105 ÷ 145 psi
Max. wheel weight	< 75 kg
Machine weight	120 kg



Zero Weight Lift

OPTION TO REDUCE ANY EFFORT

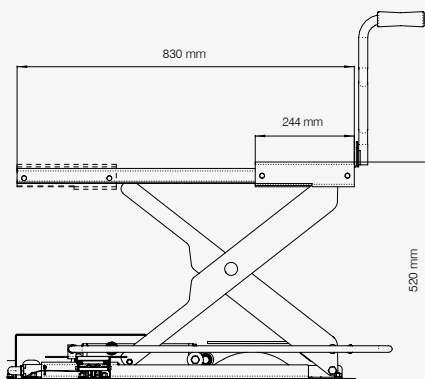

For more information see the complete brochure on the web site www.cemb.com

Wheel loading and removal without effort or adjustment

- **PERFECT CENTERING**
Wheel automatic lifting
Ideal centering and more accurate balancing
- **QUICK**
Quicker than any other traditional lift
A single pedal controls the whole working cycle
- **AUTOMATIC**
Electronic system with PLC
- **UNIVERSAL**
Applicable to any CEMB balancing machine



CEMB

BALANCING MACHINES

CEMB S.p.A.

Via Risorgimento, 9
23826 Mandello del Lario (LC) - Italy

www.cemb.com



Garage equipment division

CEMB - ITALY

Plant and Training Center

Phone +39 0341 706111

garage@cemb.com



All the data and features mentioned in this catalogue are purely for information and do not constitute any commitment on the part of our company, which reserves the right to make any and all alterations it may consider suitable without notice.