

ER85 EVO

spotter

RUN-OUT AND
BALANCING
IN ONE
SPIN ONLY

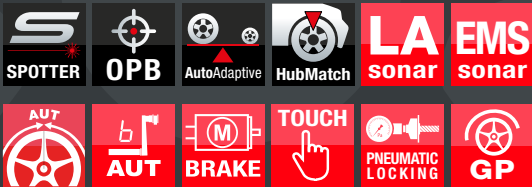

CEMB



ER85 EVO

FROM CEMB EXPERIENCE

- **ER85 EVO** balancer is the result of CEMB consolidated experience in the manufacturing of high technology garage and industrial balancers since 1946. Development and cooperation with the most important car and tyre manufacturers guarantee to the professionals in the garage equipment field:
- **Reliability**
- **Easy and quick use**
- **Accuracy**
- **Completely configurable**
- **Reduced cycle time!**

INNOVATIVE DESIGN:

ERGOFAST

- With **ER85 EVO**, CEMB widens its range of products **ERGOFAST**, maintaining the concepts of ergonomics and practicality together with the original design
- **WBA Wheel Best Access**
Wide space to work inside the rim
- Innovative touch screen
- Ergonomic tool positioning
CLOSE AT HAND!

CORE OF TECHNOLOGY

- **Laser Spotter** - Greatest accuracy in the weights positioning during the correction
- **OPB One Plane Balancing** - Correction of both static and dynamic unbalance on one plane at once and with only one weight
- **AutoAdaptive Mode** - The new tolerance calculation system
- **Sonar LA** for automatic measurement of the wheel width **CEMB PATENT**
- **Sonar EMS** (1st Harmonic and Peak to Peak) Automatic and quick eccentricity measurement during the normal balancing cycle with fast indication of possible **MATCHING**
- **ALU-S Balancing mode** - Adhesive weights on the internal rim planes with specific counterweight position indicator (position repeater)
- **Led light** to illuminate the working space inside the rim
- **Tyre Set** - The software indicates the best wheel positioning on the vehicle to get the best ride (conicity) and to minimize wheel vibrations (eccentricity)
- **HubMatch** - During the measuring cycle, the wheel's "maximum eccentricity point" is detected and displayed on monitor, therefore allowing for its reduction during the re-mounting of wheel on vehicle
- **Pneumatic wheel locking** **CEMB PATENT**
Floor to floor time reduction / Extremely easy and quick to use / Very accurate wheel centering
- **Automatic rotation and locking** of the wheel in weight position
- **Extended gauge** for diameter and distance measurement of rims up to 28"
- **VDD Virtual Direct Drive** - Very quick and maintenance free measurement system **CEMB PATENT**



PNEUMATIC LOCKING



CEMB PATENT



CEMB PATENT



SONAR LA



Laser Spotter

PERFECT BALANCING IN JUST ONE SPIN

- Greatest accuracy in weights positioning through laser spotter.
- Preview of the exact weight positioning spot visible already during the wheel dimensions acquisition phase.
- During the correction, the **LASER SPOTTER** pinpoints the exact position for stick-on weights application inside the rim. Thanks to the electric brake - which locks the wheel into the exact angular position of the unbalance - you avoid possible errors during the weight application making the balancing process faster, simpler and more precise.
- In static balancing mode, **LASER SPOTTER** detects the exact static weight location, in order to minimize the residual unbalance on the external planes.



One Plane Balancing

WHERE INNOVATION MEETS SIMPLICITY

- **OPB** (One Plane Balancing), eliminates both static and dynamic unbalance with a single counterweight, indicating the exact position to apply the weight inside the rim. The balancer automatically detects if it is possible to correct both unbalances with only one weight and activates **OPB program**. A real revolution in wheel balancing. **OPB** saves you time while maximizing your productivity.

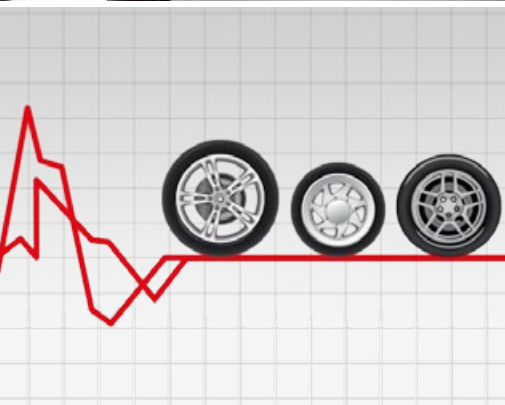

AutoAdaptive Mode

THE NEW TOLERANCE CALCULATION SYSTEM

- The innovative tolerance calculation system **AutoAdaptive Mode** is based on the evaluation of the residual imbalance limit value corresponding to an acceptable perceived vibration. For each wheel that is balanced, the software **AutoAdaptive Mode** detects weight and dimensions and calculates the tolerance value that will cancel any vibration perceived on the steering wheel. **AutoAdaptive Mode** grants the highest comfort when driving, and together with **OPB program**, saves balancing time.

In 1952 Cemb created the cone adapters for balancing machines and since then the company continued developing and producing high precision centering systems for any type of wheel. **Cemb does not recommend the use of non-original adapters on its balancing machines.**

Standard equipment UC20/SE2
composed of: SE kit, 3 cones Kit
and WDC gauge



41FF034417
SE Kit (ring, quick locking sleeve
SE2, SE spacer)



41FF034416
3 cones kit \varnothing 45÷110 mm,
pincer-hammer and 60 g. counterweight



46FC77653
Width gauge



OPTIONAL ACCESSORIES - Especially designed for car manufacturers



RL CUP 41FF79255

UH20/2 41FF42048

PEUGEOT-CITROËN KIT 41FF73171

VL/2 CONE + G36 DISC 41FF86174

SR4/SE - SR5/SE - SR5/2/SE SR/USA/SE

RENAULT KIT 41FF77152

MT CONE 40FF57321

MERCEDES KIT 41FF88003

FOR MORE INFORMATION SEE THE COMPLETE
BROCHURE ON THE WEB SITE
www.cemb.com

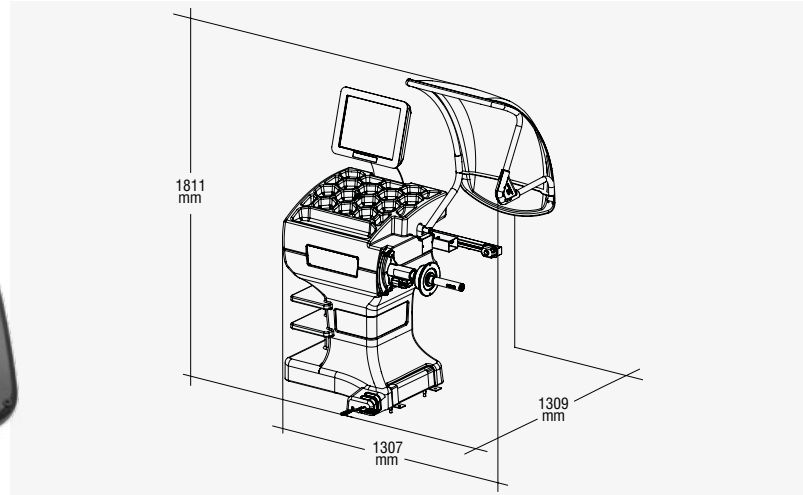

Single phase power supply	115 / 230 V 50/60 Hz
Max. absorbed power	0,15 kW
Balancing speed	100 rpm
Measuring cycle for 15 kg (33 lb) wheel	4.7 s
Measurement uncertainty	0,5 g
Average noise	< 70 dB (A)
Rim width setting range	1.5" ÷ 20" / 40 ÷ 510 mm
Rim diameter setting range	10" ÷ 30" / 265 ÷ 765 mm
Min./Max. compressed air pressure	7 ÷ 10 kg/cm ² ~ 0.7 ÷ 1 MPa ~ 7 ÷ 10 bar ~ 105 ÷ 145 psi
Max. wheel weight	< 75 kg
Machine weight	120 kg



Zero Weight Lift

OPTION TO REDUCE ANY EFFORT

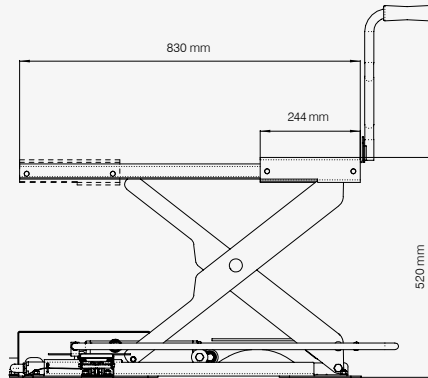

Wheel loading and removal without effort or adjustment

- **PERFECT CENTERING**
Wheel automatic lifting
Ideal centering and more accurate balancing
- **QUICK**
Quicker than any other traditional lift
A single pedal controls the whole working cycle
- **AUTOMATIC**
Electronic system with PLC
- **UNIVERSAL**
Applicable to any CEMB balancing machine

For more information see the complete brochure on the web site www.cemb.com



CEMB

BALANCING MACHINES

CEMB S.p.A.
Via Risorgimento, 9
23826 Mandello del Lario (LC) - Italy
www.cemb.com



Garage equipment division
CEMB - ITALY
Plant and Training Center
Phone +39 0341 706111
garage@cemb.com



All the data and features mentioned in this catalogue are purely for information and do not constitute any commitment on the part of our company, which reserves the right to make any and all alterations it may consider suitable without notice.